

XEV12D

ON-OFF ELECTRONIC EXPANSION VALVE DRIVERS

CONTENTS

1. General warning	1
2. General description	1
3. Regulation	1
4. Front panel	1
5. User interface	1
6. Parameters list	2
7. Digital inputs	3
8. Plant starting function	3
9. Electrical connections	3
10. RS485 serial line	3
11. How to use the HOT KEY	3
12. Display messages	3
13. Technical data	3
14. Wiring connections	3
15. Standard values	3
16. Example of application	4

1. GENERAL WARNING

1.1 PLEASE READ BEFORE USING THIS MANUAL

- This manual is part of the product and should be kept near the instrument for easy and quick reference.
- The instrument shall not be used for purposes different from those described hereunder. It cannot be used as a safety device.
- Check the application limits before proceeding.
- Dixell Srl reserves the right to change the composition of its products, even without notice, ensuring the same and unchanged functionality.

1.2 SAFETY PRECAUTIONS

- Check the supply voltage is correct before connecting the instrument.
- Do not expose to water or moisture: use the controller only within the operating limits avoiding sudden temperature changes with high atmospheric humidity to prevent formation of condensation
- Warning: disconnect all electrical connections before any kind of maintenance.
- Fit the probe where it is not accessible by the End User. The instrument must not be opened.
- In case of failure or faulty operation send the instrument back to the distributor or to "Dixell Srl." (see address) with a detailed description of the fault.
- Consider the maximum current which can be applied to each relay (see Technical Data).
- Ensure that the wires for probes, loads and the power supply are separated and far enough from each other, without crossing or intertwining.
- In case of applications in industrial environments, the use of mains filters (our mod. FT1) in parallel with inductive loads could be useful.

2. GENERAL DESCRIPTION

The XEV12D module is able to drive ON/OFF electronic expansion valves. This module permits to regulate the superheat (SH) of the fluid that runs into refrigerating unit in order to obtain optimized performance and a climatic or load conditions independent functioning. XEV12D modules are equipped with two probe inputs, one for 4÷20mA or 0÷5V pressure transducer and another for Pt1000 or NTC temperature probe. A LAN connection permits to transmit the pressure signal to all other XEV modules in order to use only one pressure transducer in multiplexed cabinet applications. There are also two configurable digital inputs, one of them must be configured to get cooling request. The other digital input can be used to signal to the instrument that defrost is in progress. The display with icons permits a useful visualisation of the superheat (SH), of the percentage of opening valve time or the probe values, the local keyboard allows to program the instrument without other devices. To complete instrument equipment, a RS485 serial link permits to connect XEV12D to Dixell monitoring and supervising systems.

3. REGULATION

The superheat regulation is performed only when the cooling request is active. The following scheme shows how device reads the request of cooling:

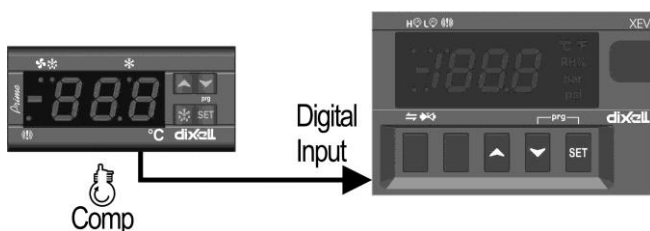

The regulation is obtained with PI controller that it changes the valve opening percentage. Opening percentage is obtained from average of Opening Time respect to CyP time period like following diagram:

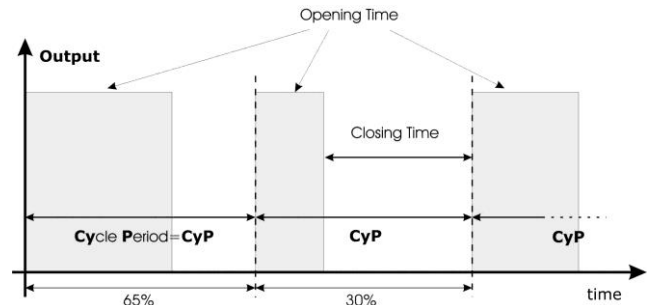

With opening percentage we mean percentage of cycle period where valve is open. For example, if CyP=6s and we say: "The valve opening percentage is 50%"; we mean the valve is opened for 3s during cycle period.

3.1 INJECTION SIGNALLING

The graph illustrates how to work the function for injection problems signalling. When superheat stays in dSH (delta SuperHeat) band and valve increases continuously its opening more than dOP (delta OPening) for ind time (injection delay) the driver signals a gas problem. When this event occurs, the behaviour of the valve can be fitted to your demand. Trough inb (injection behaviour) parameter you can choose if the valve have to close completely (inb=L), or if regulation have to continue normally with PI.

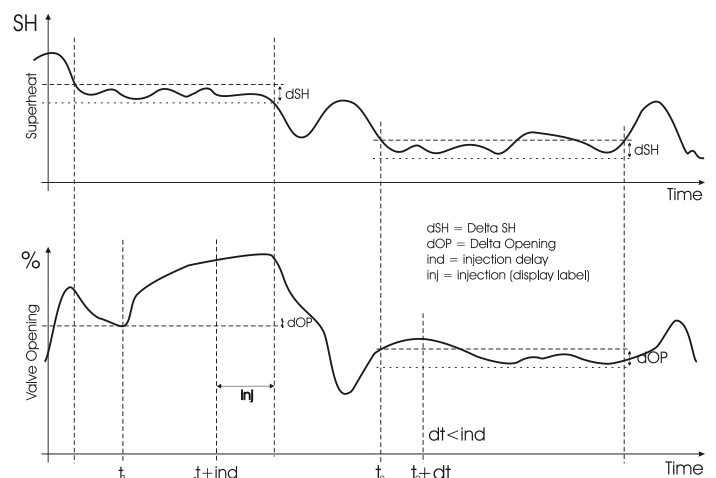

4. FRONT PANEL



SET	To display and to modify the set point. In programming mode it selects a parameter or it confirms a value.
▲	In programming mode it slides the codes of the parameters or it increases their values.
▼	In programming mode it slides the codes of parameters or it decreases their values.

KEYS COMBINATIONS

- ▼ + ▲ To lock or to unlock the keyboard.
- SET + ▼ To enter to programming mode.
- SET + ▲ Press and hold this keys combination about 5 seconds to activate valve ON function (described in Plant start section). If you are in programming mode this combination permits to leave it.

4.1 XEV12D LEDS

On display there are some luminous dots. Their meaning is described in the following table:

LED	MODE	Function
L	ON	Low pressure alarm
H	ON	Maximum Operating Pressure alarm
⏏	OFF	Valve is closed
⏏	ON	Valve is opened
↔	BLINKING	Serial communication present
↔	OFF	Serial communication absent
⚡	ON	Superheat alarm

5. USER INTERFACE

5.1 TO SEE THE READ-ONLY PARAMETERS

- 1) Press and release ▲ key;
- 2) First read-only label is showed;
- 3) Slide labels with ▲ or ▼ arrows;
- 4) Press SET to see read-only value, to change value to see press SET
- 5) To leave, press and release ▲ + SET or wait time-out of about 3 minutes.

5.2 TO SEE THE SET POINT

- 1) Press the **SET** key until the set point will be showed;
- 2) To come back to see temperature, wait about 5s or press newly **SET** key.

5.3 TO MODIFY THE SET POINT

To change the set point value operate as follows:

- 1) Press the **SET** key until the set point will be showed;
- 2) Use **▲** or **▼** to change its value.
- 3) Press **"SET"** to store the new value.

5.4 TO GO TO "PR1" PARAMETERS

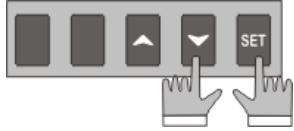

To enter in "Pr1" level menu:

- 1) Pressing **SET+▼** keys for about 3 seconds.
- 2) Instruments shows first parameter in Pr1 menu

5.5 TO GO TO "PR2" PARAMETERS



To enter to "Pr2" parameters list:

1. Enter to "Pr1"
2. Select "Pr2" parameter and press SET
3. The "PAS" label will be shown, then "0 - -" with 0 blinking.
4. Insert "321" password through **▲** and **▼** keys, then press SET to confirm.

5.6 TO MODIFY THE PARAMETERS VALUE

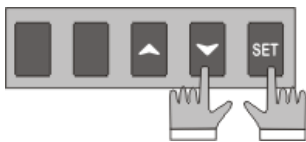

To change the parameter's value operate as follows:

1. Enter the Programming mode by pressing the Set and DOWN key for about 3s.
2. Select the required parameter.

3. Press the **"SET"** key to display its value
4. Use **▲** or **▼** to change its value.
5. Press **"SET"** to store the new value and move to the following parameter.

To exit: Press **SET + ▲** or wait 30s without pressing a key.

NOTE: the set value is stored even when the procedure is exited by waiting the time-out to expire.

6. PARAMETERS LIST

NOTE: All pressure parameters are relatives or absolutes depending on PrM parameter.

REGULATION

FtY	Kind of gas (R22, 134, 404, 407, 410, 507,CO2): Type of gas used by plant. Fundamental parameter for correct functioning of all system.
PEO	Probe Error opening percentage: (0÷100%) if a temporary probe error occurs, valve opening percentage is PEo until PEd time is elapsed.
PEd	Probe Error delay before stopping regulation: (0÷239 sec. - 240=unlimited) if probe error duration is bigger than PEd then valve totally closes. If PEd=240 valve opening is PEo until probe error finishes.
ESF	Enable Start Function: (n÷Y) n= when digital input configured as CCL is activated, normal regulation starts immediately; Y= when digital input configured as CCL is activated valve opens with OPE percentage for time Sfd .
OPE	Start opening Percentage: (0÷100%) Opening valve percentage when start function is active and during post defrost phase. This phase duration is Sfd time.
Sfd	Start Function duration: (0.0÷42.0 min: tens of seconds) It sets start function duration and post-defrost duration. During this phase the alarms are neglected
ind	injection delay: (0.0÷42.0 min: tens of seconds) view paragraph 3.1
dSH	delta SuperHeat: (0.1÷10°C / 1÷50°F) view paragraph 3.1
dOP	delta Opening Percentage: (0÷100%) view paragraph 3.1
inb	injection behaviour: (rEG ÷ cL) when an injection problem is signalled if inb=cL valve will close completely, if inb=rEG valve will regulate normally by PI (see paragraph 3.1).
Sti	Stop regulation interval: (0.0÷24.0 hours: tens of minutes) after regulating continuously for Sti time, the valve closes for Std time in order to prevent ice creation.
Std	Stop duration: (0÷60 min.) it defines stop regulation time after Sti . During this stop display shows StP message
MnF	Maximum opening percentage at normal Functioning: (0÷100%) during regulation it sets the maximum valve opening percentage.
FOt	Forced Opening time-out: (0.0÷24.0 hours: tens of minutes) If Plant starting function is enabled for all FOt time the function is disabled automatically, see Plant starting function paragraph.

PI PARAMETERS (trained staff)

CyP	Cycle Period: (1 ÷ 15s) it permits to set cycle time.
Pb	Proportional band: (0.1 ÷ 50.0 / 1÷90°F) PI proportional band
rS	Band Offset: (-12.0 ÷ 12.0°C / -21÷21°F) PI band offset
inC	Integration time: (0 ÷ 255s) PI integration time

PROBE PARAMETERS

tPP	type of Pressure transducer: (PP – LAN) it sets type of pressure transducer to use: PP= 4÷20mA pressure transducer or ratiometric transducer 0÷5V, LAN= the pressure signal arrives from another XEV module.
-----	---

PA4	Probe value At 4mA or At 0V: (-1.0 ÷ P20 bar / -14 ÷ PSI / -10 ÷ P20 kPA*10) pressure value measured by probe at 4mA or at 0V (related to PrM parameter)
P20	Probe value 20mA or At 5V: (PA4 ÷ 50.0 bar / 725 psi / 500 kPA*10) pressure value measured by probe at 20mA or at 5V (related to PrM parameter)
oPr	Pressure probe calibration: (-12.0 ÷ 12.0 bar / -174÷174 psi / -120 ÷ 120 kPA*10)
tTE	type of tEmperature probe: (PtM ÷ Ntc) it allows to set the kind of probe used by the instrument: PtM = Pt1000, nTC = NTC probe.
oTE	Temperature probe calibration: (-12.0 ÷ 12.0 °C / -21÷21 °F)

DIGITAL INPUTS

i1P	Digital Input 1 (Free of voltage) digital input polarity: (cL,OP) CL= activated when closed; OP= activated when opened
i1F	Digital Input 1 (Free of voltage) digital input function: (CCL, rL, dEF) CCL= cooling call; rL= digital input activates relay; dEF= digital input signals that defrost is active
d1d	Digital Input 1 (Free of voltage) activation delay: (0÷255 min.) this activation delay is used only if digital input is configured as rL
i2P	Digital Input 2 (High voltage) digital input polarity: (CL,OP) CL= activated when closed; OP= activated when opened
i2F	Digital Input 2 (High voltage) digital input function: (CCL, rL, dEF) CCL= cooling call; rL= digital input activates relay; dEF= digital input signals that defrost is active
d2d	Digital Input 2 (High voltage) activation delay: (0÷255 min.) this activation delay is used only if digital input is configured as rL

ALARM

dAO	Alarm delay after restarting regulation: (0.0÷42.0 min: tens of seconds) time between digital input activation (configured as CCL) and alarm signalling
tdA	Type of alarm signalled by relay: (ALL, SH, PrE, di, LOC, inJ) ALL= all alarm; SH= superheat alarm; PrE= pressure alarm; di= activation only when digital input configured as rL is activated; LOC= lock alarm in case of nPA events reached; inJ= activation in cases of injection alarm.
LPL	Lower Pressure Limit for superheat regulation: (PA4 ÷ P20 bar / psi / kPA*10) when suction pressure comes down to LPL the regulation is performed with a LPL fixed value for pressure, when pressure comes back to LPL the normal pressure value is used. (related to PrM parameter)
MOP	Maximum Operating Pressure threshold: (PA4 ÷ P20 bar / psi / kPA*10) if suction pressure exceeds maximum operating pressure value, instrument signals situation with alarm LED H (related to PrM parameter)
LOP	Lowest Operating Pressure: (PA4 ÷ P20 bar / psi / kPA*10) if the suction pressure comes down to this value a low pressure alarm is signalled with alarm LED L (related to PrM parameter)
PHy	Pressure alarm Hysteresis: (0.1 ÷ 5.0 bar / 1÷ 72 PSI / 1÷50 kPA*10) alarm hysteresis to disable alarm signalling.
dML	delta MOP-LOP: (0 ÷ 100%) when a MOP alarm occurs valve will close of the dML percentage every cycle period until MOP alarm is active. When LOP occurs valve will open of the dML percentage every cycle period until LOP alarm is active.
tPA	Maximum time between two MOP and/or LOP events: (0.0÷42.0 min: tens of seconds) time interval to calculate the number of the pressure switch activation.
nPA	Number of events before locking: (0=Off ÷ 100) number of MOP or LOP events, during the "tPA" interval, before locking instrument.
MSH	Maximum SuperHeat alarm: (LSH÷32,0°C / LSH÷176°F) when superheat exceeds this value an high superheat alarm is signalled after interval SHd
LSH	Lowest SuperHeat alarm: (0.0÷MSH °C / 32÷MSH °F) when superheat goes down to this value a low superheat alarm is signalled after interval SHd
SHy	SuperHeat alarm Hysteresis: (0.0÷25.5°C / 1÷77°F) hysteresis for superheat alarm deactivation
SHd	SuperHeat alarm activation delay: (0÷255s) when a superheat alarm occurs, the time SHd have to pass before signalling alarm
FrC	Fast-recovery Constant: (0÷100s) permits to increase integral time when SH is below the set-point. If FrC=0 fast recovery function is disabled.

DISPLAY

Lod	Local display: (SH, PEr, P1, P2) SH= superheat; PEr = valve opening percentage; P1= value of temperature measured; P2= pressure measured by P2 probe;
CF	Temperature measurement units: (°C÷°F) °C= Celsius degree; °F= Fahrenheit degree; ATTENTION: by changing measurement unit, the regulation parameters have to be correctly changed
PMu	Pressure Measurement units: (bAr, PSI, kPA*10) bAr= bar; PSI= psi; PA= KPa*10; ATTENTION: by changing measurement unit, the regulation parameters have to be correctly changed
PrM	Pressure visualization Mode: (rEL÷AbS) rEL= relative pressure; AbS= absolute pressure; All pressure parameters depend on this parameter
CLt	Cooling time statistic: (0÷48h) time interval used to evaluate a cooling call statistic. During this time comes calculated how much time the cooling call is remained active
CLP	Cooling Percentage (read only): Display the percentage of time during which the cooling call was active in the time interval defined by parameter CLt
tP1	temperature Probe value (read only): it shows temperature probe value from P1
PPr	Pressure probe value (read only): it shows pressure probe value. The value depends on PrM.
tP2	temperature from P2 (read only): it shows temperature obtained from conversion of pressure value
d1S	Free of voltage digital input State (read only): it shows the free of voltage digital input;
d2S	High voltage digital input State (read only): it shows the high voltage digital input state;
Adr	RS485 Serial Address: (1÷247) Identifies the instrument address when connected to a ModBUS compatible monitoring system.
Mod	ModBus: (AdU÷StD) AdU= (Only for XWEB3000 system) in this case XEV and the modbus controller are considered an alone instrument (it requires a custom library for XWEB); StD= to use XEV in stand-alone mode, in this case normal Modbus-RTU protocol is used;
Ptb	Parameters map: (read only) it identifies parameters map written by factory
rEL	Release Firmware: (read only) it shows firmware release
Pr2	Second level menu

7. DIGITAL INPUTS

There are two digital inputs. One of them is free of voltage and the other is at supply voltage and both can be configured as cooling call. In this way the cooling call can arrive via instruments with direct load outputs or via instruments with output without voltage. **One of these inputs must be configured as cooling call.**

8. PLANT STARTING FUNCTION

If necessary, by pressing and holding **▲ + SET** keys combination for 5 seconds the driver opens completely the valve and shows on display the **"ON"** label. To disable this function press and hold another time **▲ + SET** keys combination or activate digital input configured as CCL or wait **Fot** time out.

9. ELECTRICAL CONNECTIONS

The instrument are provided with screw terminal block to connect cables with a cross section up to 2,5 mm². Heat-resistant cables have to be used. Before connecting cables make sure the power supply complies with the instrument's requirements. Separate the probe cables from the power supply cables, from the outputs and the power connections. Do not exceed the maximum current allowed on each relay, in case of heavier loads use a suitable external relay.

9.1 PROBES

Advised temperature probe placement is illustrated in the figure. Between 0 and 180 inclination degrees respect to horizontal pipe section. For suction pressure probe there aren't particular prescriptions

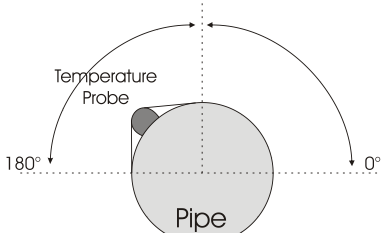

10. RS485 SERIAL LINE

All models can be connected to the monitoring and supervising system XWEB3000. If **Mod=Std** standard ModBUS-RTU protocol is used, if **Mod=AdU** custom XWEB library is required.

11. HOW TO USE THE HOT KEY

11.1 HOW TO PROGRAM A HOT KEY FROM THE INSTRUMENT (UPLOAD)

- 1) Program one controller with the front keypad.
- 2) When the controller is **ON**, insert the **"Hot key"** and push **▲** key; the **"uPL"** message appears followed a by flashing **"End"**
- 3) Push **"SET"** key and the **End** will stop flashing.
- 4) **Turn OFF** the instrument remove the **"Hot Key"**, then turn it **ON** again.

NOTE: the **"Err"** message is displayed for failed programming. In this case push again **▲** key if you want to restart the upload again or remove the **"Hot key"** to abort the operation.

11.2 HOW TO PROGRAM AN INSTRUMENT USING A HOT KEY (DOWNLOAD)

- 1) Turn OFF the instrument.
- 2) Insert a programmed **"Hot Key"** into the 5 PIN connector and then turn the Controller ON.
- 3) Automatically the parameter list of the **"Hot Key"** is downloaded into the Controller memory, the **"doL"** message is blinking followed a by flashing **"End"**.
- 4) After 10 seconds the instrument will restart working with the new parameters.
- 5) Remove the **"Hot Key"**.

NOTE the message **"Err"** is displayed for failed programming. In this case turn the unit off and then on if you want to restart the download again or remove the **"Hot key"** to abort the operation.

12. DISPLAY MESSAGES

Mess.	Cause	Outputs
"OFF"	None of digital inputs configured as CCL are activated	Valve closed
"ON"	Plant start function is activated	Valve opened
"P1"	Temperature probe fault	according to PEo and PEd
"P2"	Pressure transducer fault	according to PEo and PEd
"HSH"	High superheat alarm	By PI
"LSH"	Low superheat alarm	Valve Closed
"LPL"	Low pressure limit	see LPL parameter
"MOP"	Maximum Operating Pressure	see dML parameter
"LOP"	Lowest Operating Pressure	see dML parameter
"StF"	Start Function enabled	see ESF parameter
"StF"	Regulation stop caused by Std and Sti	Valve closed
"dEF"	Defrost in progress	Valve closed
"EE"	Memory anomaly	

12.1 ALARM RECOVERY

Probe alarms **"P1"**, **"P2"** start few seconds after the fault in the probe; they automatically stop few seconds after the probe restarts normal operation. Check connections before replacing the probe. Max. and min. alarms **"HSH"** **"LSH"** **"MOP"** **"LOP"** automatically stop as soon as the variable returns to normal values.

12.2 ALARM "EE"

The instrument is provided with an internal check verifying memory integrity. Alarm **"EE"** flashes when a failure in the internal memory is detected. In such case call the service.

13. TECHNICAL DATA

Housing: self extinguishing ABS.
Case: 4 DIN modules 70x85 mm; depth 61mm
Mounting: DIN RAIL mounted in a omega (3) din rail
Protection: IP20.
Connections: Screw terminal block ≤ 2,5 mm² wiring.
Power supply: 24Vac ±10%; 110Vac ±10%; 230Vac ±10% 50/60Hz 50/60Hz
Power absorption: 6VA max
Display: three digits with icons, red LEDs, height 14,2 mm.
Inputs: 1 temperature probe Pt1000 or NTC;
 1 pressure transducer 4÷20mA o 0÷5V;
Digital inputs: 1 free of voltage
 1 at Main voltage
Outputs for valve: 30W max
Data storage: on the non-volatile memory (EEPROM).
Kind of action: 1B; **Pollution grade:** normal; **Software Class:** A
Operating temperature: 0÷60°C; **Storage temperature:** -25÷60 °C.
Relative humidity: 20÷85% (no condensing)
Resolution: 0,1 °C or 1 °F; **Precision a 25°C:** ±0,7 °C ±1 digit

14. WIRING CONNECTIONS

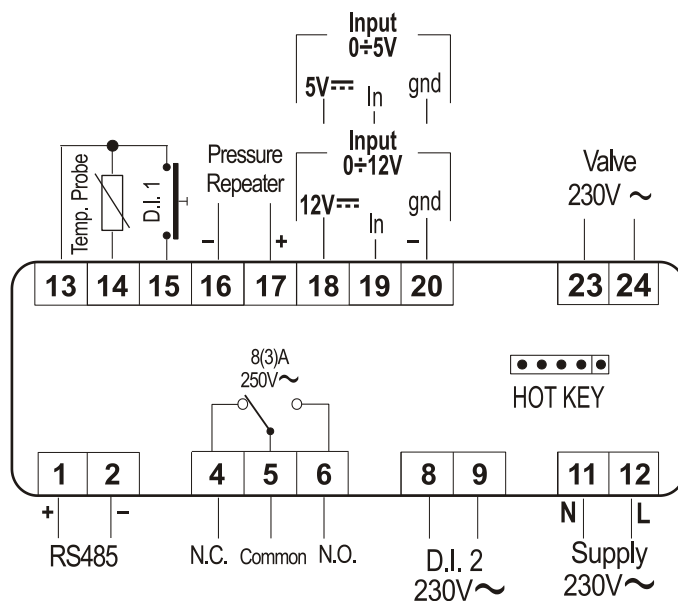

24-110Vac Models: Power supply, high voltage digital input and valve output are respectively 24Vac or 110Vac.

15. STANDARD VALUES

Label	Description	Range	Default	Level
FtY	Kind of gas	R22 , 134 , 404, 407, 410, 507, CO2	404	Pr2
PEo	Probe Error opening percentage	0 ÷ 100 %	50	Pr2
PEd	Probe Error delay before stopping regulation	0 ÷ 239 s - On	On	Pr2
ESF	Enable Start Function	n ÷ Y	Y	Pr2
OPE	Start opening Percentage	0 ÷ 100 %	85	Pr2
SFd	Start Function duration	0.0÷42.0 minutes: tens of seconds	1.3	Pr2
ind	injection delay	0.0÷42.0 minutes: tens of seconds	10.0	Pr2
dSH	delta SuperHeat	0.1 ÷ 10°C / 1÷50°F	0.1	Pr2
dOP	delta Opening Percentage	0 ÷ 100 %	100	Pr2
inb	injection behaviour	cL ÷ rEG	rEG	Pr2
Sti	Stop regulation interval	0.0÷24.0 hours: tens of minutes	1.3	Pr2
Std	Stop duration	0 ÷ 60 min.	3	Pr2
MnF	Maximum opening percentage	0 ÷ 100 %	100	Pr2
Fot	Forced Opening time-out	0.0÷24.0 hours: tens of minutes	0.1	Pr2
PI PARAMETERS (trained staff)				
CyP	Cycle Period	1 ÷ 15 s	6	Pr1
Pb	Proportional band	0.1 ÷ 50.0 °C / 1÷90 °F	4.0	Pr2
rS	Band Offset	-12.0 ÷ 12.0 °C / -21 ÷ 21°F	0.0	Pr2
inC	Integration time	0 ÷ 255 s	120	Pr2

PROBE PARAMETERS				
tPP	Type of pressure transducer	PP - LAn	PP	Pr2
PA4	Probe value at 4mA or at 0V (related to PrM parameter)	-1.0 bar / -14 PSI / -10 kPA*10 ÷ P20	-0.5	Pr2
P20	Probe value at 20mA or at 5V (related to PrM parameter)	PA4 ÷ 50.0 bar / 725 PSI / 500 kPA*10	11.0	Pr2
oPr	Pressure probe calibration	-12.0 ÷ 12.0 bar / -174 ÷ 174 psi / -120 ÷ 120 kPA*10	0	Pr2
ttE	type of tEmperature probe	PTM ÷ ntc	PTM	Pr2
otE	Temperature probe calibration	-12.0 ÷ 12.0 °C / -21 ÷ 21 °F	0	Pr2
DIGITAL INPUTS				
i1P	Free of voltage digital input polarity	cL – OP	CL	Pr2
i1F	Free of voltage digital input function	CCL , rL, DEF	CCL	Pr2
d1d	Digital input 1 (free of voltage) activation delay	0 ÷ 255 min.	0	Pr2
i2P	Main voltage digital input polarity	cL – OP	CL	Pr2
i2F	Main voltage digital input function	CCL , rL, DEF	CCL	Pr2
d2d	Digital input 2 (Main voltage) activation delay	0 ÷ 255min.	0	Pr2
ALARMS				
dAO	Alarm delay after restarting regulation	0.0÷42.0 hours: tens of seconds	3.3	Pr2
tdA	Type of alarm signalled by relay	ALL, SH, PrE, DI, LOC, inJ	ALL	Pr2
LPL	Lower pressure limit for superheat regulation (related to PrM parameter)	PA4 ÷ P20 bar / PSI / kPA*10	-0.5	Pr2
MOP	Maximum operating pressure threshold (related to PrM parameter)	PA4 ÷ P20 bar / PSI / kPA*10	11.0	Pr2
LOP	Minimum suction pressure limit (related to PrM parameter)	PA4 ÷ P20 bar / PSI / kPA*10	-0.5	Pr2
PHy	Pressure alarm Hysteresis	0.1 ÷ 5.0 bar / 1 ÷ 72 psi / 1 ÷ 50 kPA*10	0.1	Pr2
dML	delta MOP-LOP	0 ÷ 100%	30	Pr2
tPA	Maximum time between two MOP and/or LOP events	0.0÷42.0 hours: tens of seconds	0.1	Pr2
nPA	Number of events before locking	0(Off) ÷ 100	0	Pr2
MSH	Maximum superheat alarm	LSH ÷ 32.0 °C / LSH ÷ 176 °F	50.0	Pr1
LSH	Lowest superheat alarm	0.0 ÷ MSH °C / 32 ÷ MSH °F	2.5	Pr1
SHy	Superheat hysteresis	0.1 ÷ 25.5 °C / 1 ÷ 77°F	0.5	Pr2
SHd	Superheat alarm activation delay	0 ÷ 255 s	10	Pr1
FrC	Fast-Recovery Constant	0÷100 s	50	Pr2
DISPLAY				
Lod	Local display	SH - PEr - P1 - P2	SH	Pr1
CF	Temperature measurement units	°C - °F	°C	Pr2
PMu	Pressure measurement unit	bAr - PSI - PA	bAr	Pr2
PrM	Type of pressure (Absolute / relative)	rEL - AbS	rEL	Pr2
CLt	Time to evaluate Cooling statistic	0 ÷ 48 hours	48	Pr1
CLP	Cooling call percentage	Read only	---	Pr2
tP1	Temperature probe value	Read only	---	Pr1
PPr	Pressure probe value	Read only	---	Pr1
tP2	Temperature converted from pressure probe	Read only	---	Pr1
d1S	Free of voltage digital input state	Read only	---	Pr1
d2S	Main voltage digital input state	Read only	---	Pr1
Adr	Serial address	1÷247	1	Pr2
Mod	Modbus type	Std - AdU	StD	Pr2
Ptb	Parameters map	---	---	Pr2
rEL	Release software	---	---	Pr2
Pr2	Second level menu	---	---	Pr1

16. EXAMPLE OF APPLICATION

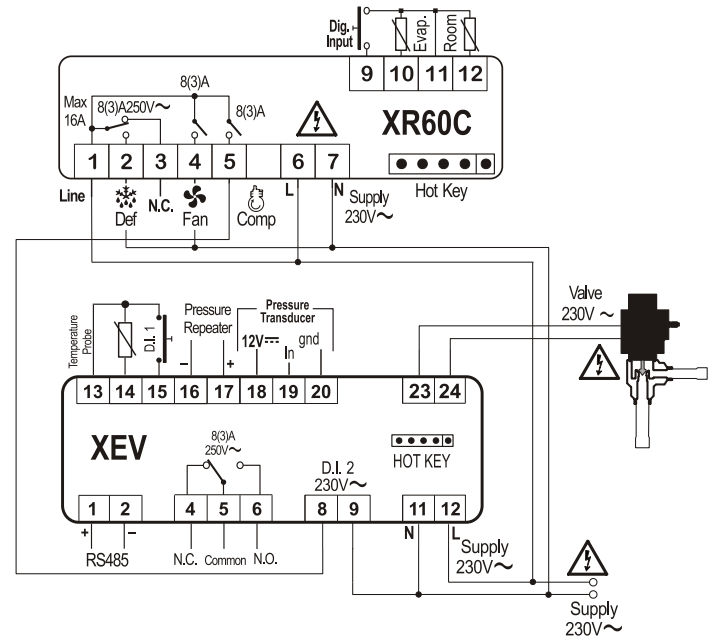



Dixell S.r.l. - Z.I. Via dell'Industria, 27 - 32010 Pieve d'Alpago (BL) ITALY
 Tel. +39.0437.9833 r.a. - Fax +39.0437.989313 - EmersonClimate.com/Dixell - dixell@emerson.com