



iPro SERIES

(v.3.5)



INDEX

1.	IMPORTANT RECOMMENDATIONS	5
1.1	PRODUCT DISPOSAL (WEEE)	6
2.	INTRODUCTION	7
3.	GENERAL SPECIFICATIONS	7
3.1	PROCESSING ENVIRONMENT	7
3.1.1	Fields of application.....	7
3.1.2	Hardware architecture	7
3.2	RELEVANT DATA	8
4.	VERSIONS OF THE PROGRAMMABLE CONTROLLERS	9
4.1	IPRO.GENIUS AND IPRO.CHILL (IPG100D – IPC100D RANGES)	10
4.1.1	Description of the connections.....	11
4.1.2	Description of the inputs and outputs.....	12
4.1.3	Technical specifications.....	14
4.1.3.1	Analogue inputs.....	14
4.1.3.2	Digital inputs.....	14
4.1.3.3	Analogue outputs.....	14
4.1.3.4	Standard Digital outputs.....	15
4.1.3.5	SSR Digital outputs version	15
4.1.3.6	Wiring diagrams.....	15
4.1.3.7	Mechanical specifications	16
4.1.3.8	Electrical specifications.....	16
4.1.3.9	Plastic container	16
4.1.3.10	Product certifications	17
4.2	IPRO.GENIUS (IPG200D RANGE)	18
4.2.1	Description of the connections.....	18
4.2.2	Description of the inputs and outputs.....	19
4.2.3	Technical specifications.....	21
4.2.3.1	Analogue inputs.....	21
4.2.3.2	Digital inputs.....	21
4.2.3.3	Analogue outputs.....	21
4.2.3.4	Digital outputs.....	22
4.2.3.5	Wiring diagrams.....	22
4.2.3.6	Mechanical specifications	23
4.2.3.7	Electrical specifications.....	23
4.2.3.8	Plastic container	23
4.2.3.9	Product certifications	23
4.3	IPRO.GENIUS AND IPRO.CHILL (IPG300D – IPC300D RANGES)	24
4.3.1	Description of the connections.....	25
4.3.2	Description of the inputs and outputs.....	26
4.3.3	Technical specifications.....	28
4.3.3.1	Analogue inputs.....	28
4.3.3.2	Digital inputs.....	28
4.3.3.3	Analogue outputs.....	28
4.3.3.4	Standard Digital outputs.....	29
4.3.3.5	Wiring diagrams.....	29
4.3.3.6	Mechanical specifications	30
4.3.3.7	Electrical specifications.....	30
4.3.3.8	Plastic container	30
4.3.3.9	Product certifications	30
4.4	IPRO.GENIUS (IPG800D RANGES)	31
4.4.1	Description of the connections.....	31
4.4.2	Description of the inputs and outputs.....	32
4.4.3	Technical specifications.....	33
4.4.3.1	Analogue inputs.....	33
4.4.3.2	Digital inputs.....	34
4.4.3.3	Analogue outputs.....	34
4.4.3.4	Digital outputs.....	34
4.4.3.5	Wiring diagrams.....	35
4.4.3.6	Mechanical specifications	35
4.4.3.7	Electrical specifications.....	35
4.4.3.8	Plastic container	36
4.4.3.9	Product certifications	36
4.5	IPRO 4 DIN (IPG100D – IPG200D – IPC100E RANGES)	37
4.5.1	Description of the connections.....	38
4.5.2	Description of the inputs and outputs.....	38
4.5.3	Technical specifications.....	39
4.5.3.1	Analogue inputs.....	39

4.5.3.2	Digital inputs	39
4.5.3.3	Analogue outputs	40
4.5.3.4	Digital outputs	40
4.5.3.5	Wiring diagrams	40
4.5.3.6	Mechanical specifications	41
4.5.3.7	Electrical specifications	41
4.5.3.8	Plastic container	41
4.5.3.9	USB-ETHERNET Adapter (Dixell specification)	41
4.6	IPRO.LINK (IPL500D)	42
4.6.1	Description of the connections	42
4.6.2	Description of the inputs and outputs	43
4.6.3	Technical specifications	43
4.6.3.1	Wiring diagrams	43
4.6.3.2	Mechanical specifications	44
4.6.3.3	Electrical specifications	44
4.6.3.4	Plastic container	44
4.7	IPX106D	45
4.7.1	Description of the connections	45
4.7.2	Description of the inputs and outputs	46
4.7.3	Technical specifications	47
4.7.3.1	Analogue inputs	47
4.7.3.2	Digital inputs	47
4.7.3.3	Analogue outputs	47
4.7.3.4	Digital outputs	47
4.7.3.5	Wiring diagrams	48
4.7.3.6	Mechanical specifications	48
4.7.3.7	Electrical specifications	48
4.7.3.8	Plastic container	49
4.7.3.9	Setting the address of the device	49
4.8	IPX206D – IPX306D	50
4.8.1	Description of the connections	50
4.8.2	Description of the inputs and outputs	51
4.8.3	Technical specifications	52
4.8.3.1	Analogue inputs	52
4.8.3.2	Digital inputs	52
4.8.3.3	Analogue outputs	52
4.8.3.4	Digital outputs	52
4.8.3.5	Wiring diagrams	53
4.8.3.6	Mechanical specifications	53
4.8.3.7	Electrical specifications	54
4.8.3.8	Plastic container	54
4.8.3.9	Setting the address of the device	54
4.9	IPX115D – IPX125D	55
4.9.1	Description of the connections	55
4.9.2	Description of the inputs and outputs	56
4.9.3	Technical specifications	58
4.9.3.1	Analogue inputs	58
4.9.3.2	Digital inputs	58
4.9.3.3	Analogue outputs	58
4.9.3.4	Digital outputs	59
4.9.3.5	Wiring diagrams	59
4.9.3.6	Mechanical specifications	60
4.9.3.7	Electrical specifications	60
4.9.3.8	Plastic container	60
4.9.3.9	Setting the address of the device	60
4.10	IPX215D – IPX225D	61
4.10.1	Description of the connections	61
4.10.2	Description of the inputs and outputs	62
4.10.3	Technical specifications	64
4.10.3.1	Analogue inputs	64
4.10.3.2	Digital inputs	64
4.10.3.3	Analogue outputs	64
4.10.3.4	Digital outputs	65
4.10.3.5	Wiring diagrams	65
4.10.3.6	Mechanical specifications	66
4.10.3.7	Electrical specifications	66
4.10.3.8	Plastic container	66
4.10.3.9	Setting the address of the device	66
4.11	IPX315D	67
4.11.1	Description of the connections	67
4.11.2	Description of the inputs and outputs	68
4.11.3	Technical specifications	70
4.11.3.1	Analogue inputs	70
4.11.3.2	Digital inputs	70
4.11.3.3	Analogue outputs	70
4.11.3.4	Digital outputs	71
4.11.3.5	Wiring diagrams	71
4.11.3.6	Mechanical specifications	72
4.11.3.7	Electrical specifications	72
4.11.3.8	Plastic container	72

4.11.3.9	Setting the address of the device.....	72
5.	INTERFACE	73
5.1	VISOGRAPH	73
5.1.1	Specifications	73
5.1.2	Connections	74
5.1.3	Options menu.....	74
5.1.4	Dimensions	75
6.	MEANING OF THE LEDS AND JUMPERS IN THE VARIOUS DEVICES	76
6.1	PROGRAMMABLE CONTROLLERS	76
6.2	EXPANSION MODULES	76
7.	INSTALLATION	77
7.1	GENERAL RULES	77
7.2	POWER SUPPLY	77
7.3	CONNECTION OF THE ANALOGUE INPUTS	78
7.3.1	Temperature probes (NTC and PTC).....	78
7.3.2	Temperature probes IPG800 Series (NTC, PTC and PT1000).....	78
7.3.3	Pressure transducers and current probes (0 - 20mA, 4 - 20mA).....	79
7.3.4	Pressure transducers and current probes IPG800 Series (0 - 20mA, 4 - 20mA)	79
7.3.5	Pressure transducers and ratiometric pressure transducers (0 - 5V).....	80
7.3.6	Pressure transducers and ratiometric pressure transducers IPG800 Series (0 - 5V).....	80
7.3.7	Live probes (0 - 1V, 0 - 5V, 0 - 10V)	81
7.3.8	Live probes IPG800 Series (0 - 1V, 0 - 5V, 0 - 10V).....	81
7.3.9	Probes and transducers with 24Vac/dc power supply	82
7.3.10	Probes and transducers with 24Vac/dc power supply IPG800 Series.....	83
7.4	CONNECTION OF THE DIGITAL INPUTS	84
7.4.1	Potential-free digital inputs	84
7.4.2	Potential-free digital inputs IPG800 Series.....	85
7.4.3	Live digital inputs (24Vac/dc).....	85
7.4.4	Power supply 24Vac digital inputs IPG800 Series	86
7.5	CONNECTION OF THE ANALOGUE OUTPUTS	87
7.5.1	0 - 10V, 4 - 20mA Analogue output for condensation control	87
7.5.2	0-10Vdc, 4-20mA Analogue output for fan speed control IPG800 Series	88
7.5.3	PWM analogue output for condensation control.....	88
7.5.4	PWM analogue output for control IPG800 Series.....	89
7.5.5	0 - 10V, 4 - 20mA Proportional analogue output for servomotors/actuators	89
7.5.6	Devices with 24Vac/dc power supply	90
7.5.7	Analogue output for relays (coil power supply 12Vdc).....	91
7.6	CONNECTION OF THE DIGITAL OUTPUTS	91
7.7	ELECTRONIC EXPANSION VALVE DRIVER IPG800 SERIES	91
7.7.1	GENERAL RULES	91
7.7.2	ELECTRICAL CONNECTIONS	92
7.8	CANBUS CONNECTION	93
7.9	RS485 SLAVE CONNECTIONS	94
7.10	RS485 MASTER CONNECTION	95

1. IMPORTANT RECOMMENDATIONS

- The  symbol alerts the user of non-insulated “dangerous voltage” within the product area that is sufficiently high to constitute a risk of electric shock to persons.
- The  symbol alerts the user of important operating and maintenance (assistance) instructions found in the documentation attached to the device.
- Dixell Srl cannot accept any liability for damages caused by modems that are not supported. Dixell Srl reserves the right to modify this manual without prior notice. The documentation can be downloaded from www.dixell.com even prior to purchase.
- This manual forms part of the product and must always be kept near the device for easy and quick reference. The device cannot be used as a safety device. Verify the limits of application before using the device.
- Verify that the power supply voltage is correct before connecting the device. Do not expose it to water or humidity: use the controller only within the operating limits, avoiding sudden changes in temperature and high atmospheric humidity in order to prevent condensation from forming. Recommendation: disconnect all the electric connections before performing any maintenance. Insert the probe where it cannot be reached by the End User. The device must not be opened. Consider the maximum current that can be applied to each relay. Make sure that the wires for the probes, the loads and the electrical power supply are separated and sufficiently distant from each other, without crossing or intertwining with each other. In the case of applications in industrial environments, it may be useful to use the main filters (our mod. FT1) in parallel to the inductive loads.
- The customer shall bear full responsibility and risk for product configuration in order to achieve the results pertaining to installation and/or final equipment/system. Upon the customer's request and following a specific agreement, Dixell s.r.l. may be present during the start-up of the final machine/application, as a consultant, however, under no circumstances can the company be held responsible for the correct operation of the final equipment/system.
- Since Dixell products form part of a very high level of technology, a qualification/configuration/programming/commissioning stage is required to use them as best as possible. Otherwise, these products may malfunction and Dixell cannot be held responsible. The product must not be used in any way that differs from that stipulated in the documentation.
- The device must always be inserted inside an electrical panel that can only be accessed by authorised personnel. For safety purposes, the keyboard must be the only part that can be reached.
- The device must never be hand-held while being used.
- It is good practice to bear the following in mind for all Dixell products:
 - Prevent the electronic circuits from getting wet as contact made with water, humidity or any other type of liquid can damage them. Comply with the temperature and humidity limits specified in the manual in order to store the product correctly.
 - The device must not be installed in particularly hot environments as high temperatures can damage it (electronic circuits and/or plastic components forming part of the casing). Comply with the temperature and humidity limits specified in the manual in order to store the product correctly.
 - Under no circumstances is the device to be opened - the user does not require the internal components. Please contact qualified service personnel for any assistance.

- Prevent the device from being dropped, knocked or shaken as either can cause irreparable damage.
- Do not clean the device with corrosive chemical products, solvents or aggressive detergents.
- The device must not be used in applications that differ from that specified in the following material.



➤ ***Separate the power of the device from the rest of the electrical devices connected inside the electrical panel. The secondary of the transformer must never be connected to the earth.***

- Dixell Srl reserves the right to change the composition of its products, even without notice, ensuring the same and unchanged functionality."

1.1 PRODUCT DISPOSAL (WEEE)

With reference to Directive 2002/96/EC of the European Parliament and of the Council of 27 January 2003 and to the relative national legislation, please note that:

- There lies the obligation not to dispose of electrical and electronic waste as municipal waste but to separate the waste.
- Public or private collection points must be used to dispose of the goods in accordance with local laws. Furthermore, at the end of the product's life, it is also possible to return this to the retailer when a new purchase is made.
- This equipment may contain hazardous substances. Improper use or incorrect disposal can have adverse effects on human health and the environment.
- The symbol shown on the product or the package indicates that the product has been placed on the market after 13 August 2005 and must be disposed of as separated waste.
- Should the product be disposed of incorrectly, sanctions may be applied as stipulated in applicable local regulations regarding waste disposal.

2. INTRODUCTION

The iPRO is the range of programmable controllers manufactured by Dixell.

The range consists of programmable controllers, I/O expansions, drivers for electronic valves and graphical interfaces adapted to cover any type of application in the air-conditioning sector, cooling sector and any relative area. As the system is one of the most technologically advanced, it is flexible and can be customised for it to be adapted to the user's particular requirements.

3. GENERAL SPECIFICATIONS

The Dixell programmable controllers are all powered at 24Vac/dc and use a high speed performance 32-bit ARM9 (200 MHz) microprocessor. The models differ in size (10 DIN or 4 DIN) and number of inputs and outputs (analogue and digital).

One of the features that distinguish the iPRO controllers is the wide range of connection options with external Dixell devices and, as well, third part devices. CANBus, RS485 Master and Slave, and an Ethernet and USB port provide maximum flexibility of integration with the outside world. MODBUS RTU protocol, one of the most popular in the world, is used for serial communication.

Up to 80 MB of flash memory are entirely available to the user, according to the model. All the inputs and outputs are fully configurable.

3.1 PROCESSING ENVIRONMENT

All Dixell programmable controllers use the following software as a processing environment:

- ISaGRAF® to process the iPRO application.
- VISOPROG to process the LCD graphic interface application (VISOGRAPH)

ISaGRAF® software is used worldwide and allows those with no programming experience to build applications ranging from the simplest to the more sophisticated. The vast range of the most popular programming languages (Structured Text, Function Block Diagram, Ladder Diagram, Instruction List, Sequential Function Chart, Flow Chart, FBD IEC 61499) provides all programmers with access to the processing environment. Thanks also to the extensive libraries of blocks already developed by Dixell, the processing and debug times are reduced.

The SIMULATION (verification of the application without using the controller) and DEBUG options (verification of the actual application within the controller), allow the user to block and force the value of the variables to speed up the testing times.

3.1.1 Fields of application

The possibility of all-round configuration allows the Dixell iPRO programmable controller to be used for any type of application. The same applications can be downloaded in the various models available (obviously adapting the number of inputs and outputs).

The hardware has already been used for the following applications:

- Chillers and heat pumps
- Air treatment units
- Air-conditioners
- Roof-tops
- Cooling systems
- Energy saving management in systems
- Climatic chamber control
- Cold rooms and seasoner cabinets

3.1.2 Hardware architecture

The iPRO programmable controller is structured as follows:

- 32-bit microprocessor used to run the application
- Removable connectors (Molex) or bayonet connectors (Phoenix)
- The programme and parameters are stored in a permanent flash memory. No data is lost in case of power failure.
- Internal web server with the Dixell website as default with the option of downloading a customised website for reading and writing variables with synoptic creation (via HTML).
- Ethernet port.
- USB port.

- Connection to the dedicated remote LCD display.
- CANBus.
- RS485 Master.
- RS485 Slave.

The remote LCD display has the following features:

- 240x96 pixel LCD graphic display.
- 32-bit processor.
- Multilingual in ASCII or UNICODE version.
- 8 fully programmable keys.
- Panel or wall mounted.

The LED display (only for the 4 DIN versions) has the following features:

- Configurable digits and icons
- 6 fully programmable keys

3.2 RELEVANT DATA

Operating temperature:	-10 to +60°C (14 to 140°F)
Relative humidity:	20 to 85%

4. VERSIONS OF THE PROGRAMMABLE CONTROLLERS

10 DIN versions:

- ***I.PRO.GENIUS***
 - IPG115D (15 relays, no application, disconnectable connectors + molex connectors)
 - IPG115D SSR (15 relays, no application, disconnectable connectors + molex connectors)
 - IPG215D (15 relays, no application, spring connectors + screw connectors)
 - IPG315D (15 relays, no application, disconnectable connectors + screw connectors)
 - IPG315D SSR (15 relays, no application, disconnectable connectors + screw connectors)

- ***I.PRO.CHILL***
 - IPC115D (15 relays, with application chiller/heatpump, disconnectable connectors + molex connectors)
 - IPC115D SSR (15 relays, with application chiller/heatpump, disconnectable connectors + molex connectors)

- ***EXPANSION***
 - IPX115D (15 relay, disconnectable connectors + molex connectors)
 - IPX125D (25 relay, disconnectable connectors + molex connectors)
 - IPX215D (15 relay, spring connectors + screw connectors)
 - IPX225D (25 relay, spring connectors + screw connectors)
 - IPX315D (15 relay, disconnectable connectors + screw connectors)

4 DIN versions:

- ***I.PRO.GENIUS***
 - IPG108D (8 relays, no application, disconnectable connectors + screw connectors)
 - IPG208D (8 relays, no application, spring connectors + screw connectors)
 - IPG108E (8 relays, LED display, without application, disconnectable connectors + screw connectors)
 - IPG208E (8 relays, LED display, without application, spring connectors + screw connectors)

- ***I.PRO.CHILL***
 - IPC108E (8 relays, LED display, with application chiller/heatpump, disconnectable connectors + screw connectors)







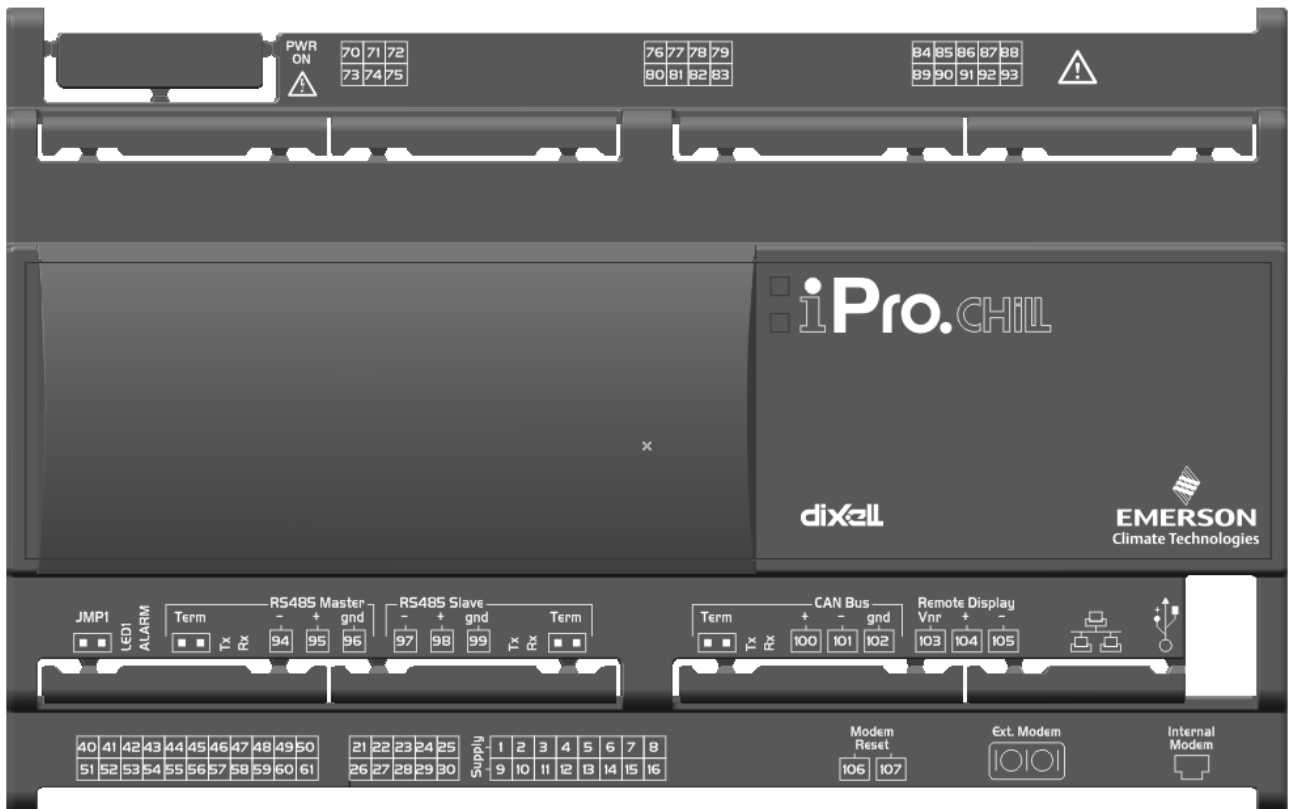
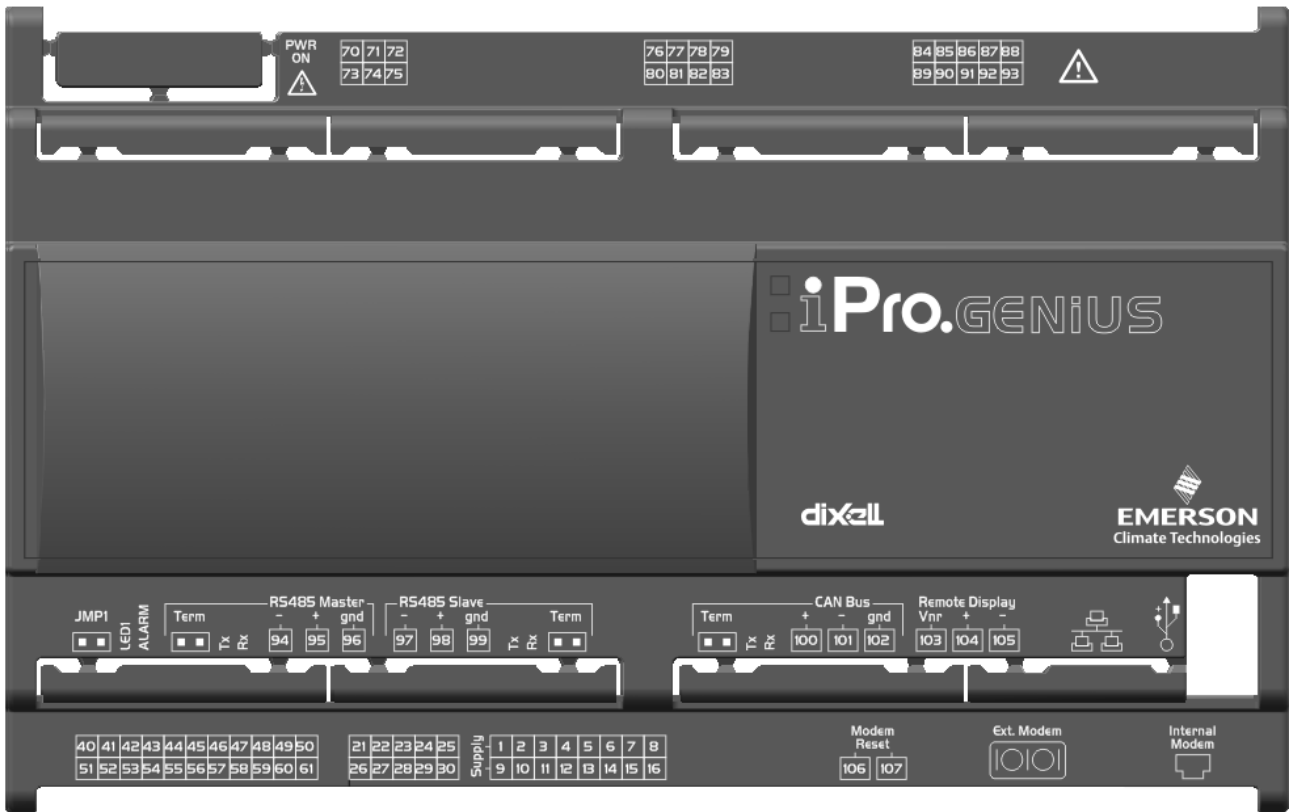









- ***I.PRO.LINK***
 - IPL500D (connectivity module)

- ***EXPANSION***
 - IPX106D (6 relay, disconnectable connectors + molex connectors)
 - IPX206D (6 relay, spring connectors + screw connectors)
 - IPX306D (6 relay, disconnectable connectors + screw connectors)

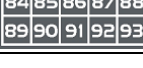
4.1 IPro.GENIUS AND IPro.CHILL (IPG100D – IPC100D RANGES)



4.1.1 Description of the connections

Connector	Description
	Connector for 24Vac/dc power supply Analogue inputs (Pb1 - Pb10, PbC) Additional power (+5Vdc, +12Vdc, GND)
	Analogue outputs (Out1 - Out6, TF1 - T2) Additional power (+12Vdc, GND)
	Potential free opto-insulated digital inputs (DI1 - DI20, DIC)
	USB port for downloads (BIOS, ISaGRAF® application, maps of parameters, remote display applications, network configuration, website) and uploads (log files)
	TCP/IP Ethernet port
	Connector for remote terminal (VISOGRAPH), maximum 2 terminals per iPRO.
	CANBUS connector for expansions (IPEX) and drivers for electronic valves (XEV20D) Rx and Tx LED to indicate that communication is active Line terminal (Term)
	RS485 Slave connector Rx and Tx LED to indicate that communication is active Line terminal (Term)
	RS485 Master connector Rx and Tx LED to indicate that communication is active Line terminal (Term)
	Digital relay outputs (115D, 110D, 415D, 410D versions) 3 NO relays + 1 changeover relay, 1 common
	Digital relay outputs (115D, 110D, 415D, 410D versions) 6 NO relays, 2 common
	Digital relay outputs (only for 115D and 415D versions) 3 NO relays + 2 changeover relays, 3 common (for 115D and 415D versions) 5 relays SSR (for 415D SSR version) *** different connection ***
	Green LED to indicate the presence of power
	Jumper to activate the RESCUE MODE
	Yellow status LEDs (LED1) and red LED (ALARM) See relative paragraph
	Connector for NC contact to reset an external modem
	RS232 connector for an external GSM modem connection (SIEMENS TC35)
	Connector for the internal analogue modem

4.1.2 Description of the inputs and outputs

Input No.	Type of Input	Description
1	Supply	Reference “-“/GND power (24Vac or 24Vdc)
2	Pb1	Configurable analogue input 1 (NTC, PTC, 0 - 20mA, 4 - 20mA, 0 - 10V, 0 - 1V, 0 - 5V, DI)
3	Pb2	Configurable analogue input 2 (NTC, PTC, 0 - 20mA, 4 - 20mA, 0 - 10V, 0 - 1V, 0 - 5V, DI)
4	Pb3	Configurable analogue input 3 (NTC, PTC, 0 - 20mA, 4 - 20mA, 0 - 10V, 0 - 1V, 0 - 5V, DI)
5	Pb4	Configurable analogue input 4 (NTC, PTC, 0 - 20mA, 4 - 20mA, 0 - 10V, 0 - 1V, 0 - 5V, DI)
6	Pb5	Configurable analogue input 5 (NTC, PTC, 0 - 20mA, 4 - 20mA, 0 - 10V, 0 - 1V, 0 - 5V, DI)
7	PbC	Common analogue inputs (NTC, PTC, DI)
8	GND (-)	Additional power reference 5Vdc and 12Vdc and analogue inputs (0 - 20mA, 4 - 20mA, 0 - 10V, 0 - 1V, 0 - 5V)
9	Supply	Reference “+“ power supply (24Vac or 24Vdc)
10	Pb6	Configurable analogue input 6 (NTC, PTC, 0 - 20mA, 4 - 20mA, 0 - 10V, 0 - 1V, 0 - 5V, DI)
11	Pb7	Configurable analogue input 7 (NTC, PTC, 0 - 20mA, 4 - 20mA, 0 - 10V, 0 - 1V, 0 - 5V, DI)
12	Pb8	Configurable analogue input 8 (NTC, PTC, 0 - 20mA, 4 - 20mA, 0 - 10V, 0 - 1V, 0 - 5V, DI)
13	Pb9	Configurable analogue input 9 (NTC, PTC, 0 - 20mA, 4 - 20mA, 0 - 10V, 0 - 1V, 0 - 5V, DI)
14	Pb10	Configurable analogue input 10 (NTC, PTC, 0 - 20mA, 4 - 20mA, 0 - 10V, 0 - 1V, 0 - 5V, DI)
15	+5V	Additional power +5Vdc
16	+12V	Additional power +12Vdc
21	Out1	Analogue output 1 0 - 10V
22	Out2	Analogue output 2 0 - 10V
23	Out3	Analogue output 3 0 - 10V
24	Out4	Analogue output 4 0 - 10V
25	GND(-)	Additional power reference 12Vdc and analogue outputs
26	Out5	Analogue output 5 0 - 10V, 4 - 20mA, Relay (if TF1 is not used)
27	Out6	Analogue output 6 0 - 10V, 4 - 20mA, Relay (if TF2 is not used)
28	TF1	Analogue output TF1 PWM (if Out5 is not used)
29	TF2	Analogue output TF2 PWM (if Out6 is not used)
30	+12V	Additional power +12Vdc
40	DI1	Opto-insulated digital input 1 (potential free contact)
41	DI2	Opto-insulated digital input 2 (potential free contact)
42	DI3	Opto-insulated digital input 3 (potential free contact)
43	DI4	Opto-insulated digital input 4 (potential free contact)
44	DI5	Opto-insulated digital input 5 (potential free contact)
45	DI6	Opto-insulated digital input 6 (potential free contact)
46	DI7	Opto-insulated digital input 7 (potential free contact)
47	DI8	Opto-insulated digital input 8 (potential free contact)
48	DI9	Opto-insulated digital input 9 (potential free contact)
49	DI10	Opto-insulated digital input 10 (potential free contact)
50	DIC	Common opto-insulated digital inputs 1 to 20
51	DI11	Opto-insulated digital input 11 (potential free contact)
52	DI12	Opto-insulated digital input 12 (potential free contact)
53	DI13	Opto-insulated digital input 13 (potential free contact)
54	DI14	Opto-insulated digital input 14 (potential free contact)
55	DI15	Opto-insulated digital input 15 (potential free contact)
56	DI16	Opto-insulated digital input 16 (potential free contact)
57	DI17	Opto-insulated digital input 17 (potential free contact)
58	DI18	Opto-insulated digital input 18 (potential free contact)
59	DI19	Opto-insulated digital input 19 (potential free contact)

60	DI20	Opto-insulated digital input 20 (potential free contact)
61	DIC	Common digital inputs 1 to 20
70	RL1	Relay 1 normally open contact
71	RL2	Relay 2 normally open contact
72	RL3	Relay 3 normally open contact
73	C	Common relays 1, 2, 3 and 4 (MAX 6A)
74	RL4	Relay 4 normally open contact
75	RL3	Relay 3 normally closed contact
76	C	Common relays 5, 8 and 9 (MAX 6A)
77	RL5	Relay 5 normally open contact
78	RL6	Relay 6 normally open contact
79	RL7	Relay 7 normally open contact
80	RL8	Relay 8 normally open contact
81	RL9	Relay 9 normally open contact
82	RL10	Relay 10 normally open contact
83	C	Common relays 6, 7 and 10 (MAX 6A)
84	RL11	Relay 11 normally open contact
85	RL12	Relay 12 normally open contact
86	RL13	Relay 13 normally open contact
87	C	Common relays 12, 13 and 15 (MAX 6A)
88	C	Common relays 12, 13 and 15 (MAX 6A)
89	RL11	Relay 11 normally closed contact
90	C	Common relays 11 and 14 (MAX 6A)
91	RL14	Relay 14 normally open contact
92	RL14	Relay 14 normally closed contact
93	RL15	Relay 15 normally open contact
94	RS485 Master	RS485 Master connection (-)
95	RS485 Master	RS485 Master connection (+)
96	RS485 Master	RS485 Master connection (insulated gnd)
97	RS485 Slave	RS485 Slave connection (-)
98	RS485 Slave	RS485 Slave connection (+)
99	RS485 Slave	RS485 Slave connection (insulated gnd)
100	CAN Bus	CAN Bus connection (+), not open
101	CAN Bus	CAN Bus connection (-), not open
102	CAN Bus	CAN Bus connection (insulated gnd), not open
103	Remote Display	Connection for VISOGRAPH remote terminal (Vnr)
104	Remote Display	Connection for VISOGRAPH remote terminal (+)
105	Remote Display	Connection for VISOGRAPH remote terminal (-)
106	Modem Reset	NC relay input to reset an external modem (24Vac/dc)
107	Modem Reset	NC relay output to reset an external modem (24Vac/dc)

Version with SSR relay

84	RL11	Relay 11 normally open contact
85	RL11	Common relays 11
86	RL12	Relay 12 normally open contact
87	RL12	Common relays 12
88	RL13	Common relays 13
89	RL14	Relay 14 normally open contact
90	RL14	Common relays 14

91	RL15	Relay 15 normally open contact
92	RL15	Common relays 15
93	RL13	Relay 13 normally open contact

4.1.3 Technical specifications

4.1.3.1 Analogue inputs

Analogue conversion type:	10-bit A/D converter
Number of inputs:	10
Type of analogue input: (configurable via software parameter)	NTC Dixell (-50T110°C; 10KΩ±1% at 25°C) PTC Dixell(-55T115°C; 990Ω±1% at 25°C) Digital input (potential free contact) Voltage: 0 - V, 0 - 5V, 0 - 10V (input resistance 3.7KΩ) Current: 0 - 20mA, 4 - 20mA (input resistance 100Ω)
Digital input status variation detection time:	100ms (in any case it depends on the cycle time set by the user in the given application)
Accuracy:	NTC, PTC: ±1°C 0-1V: ±20mV 0-5V: ±100mV 0-10V: ±200mV 2-20mA, 4-20mA: ±0.30mA
Additional power:	+12V: 200mA in total (between +12V and analogue outputs) +5v: 100mA
Notes: 	Any inputs that are powered with a voltage that differs from that supplied by the device (+12V or +5V) must be powered separately with another transformer (do not use the same secondary of the controller's power) in order to prevent the inputs from malfunctioning or being damaged.

4.1.3.2 Digital inputs

Type: (configurable via software parameter)	Opto-insulated potential free contact
Number of inputs:	20
Digital input status variation detection time:	100ms (in any case it depends on the cycle time set by the user in the given application)
Notes: 	Do not use live contacts in order to prevent the inputs from being damaged.

4.1.3.3 Analogue outputs

Type:	Non opto-insulated internal power
Number of outputs:	6
Type of analogue output: (configurable via software parameter)	4 fixed outputs 0-10Vdc (Out1 - Out4) 2 configurable outputs (alternative): - 0-10Vdc, 4-20mA (Out5 and Out6) - PWM to be used with Dixell XV modules (TF1 and TF2)
Maximum load:	40mA (Out1 - Out4) 20mA (Out5 and Out6) max with configured outputs 0-10Vdc 400Ω max with configured outputs 4-20mA 22Ω per live analogue output
Accuracy:	Out1 - Out4: ±2% full scale Out5 - Out6: ±2% full scale
Resolution:	8bit
Notes: 	The electrical devices controlled by these analogue outputs must be powered separately with another transformer (do not use the same secondary of the controller's power) in order to prevent the outputs from malfunctioning or being damaged.

4.1.3.4 Standard Digital outputs

Type:	Relays with NO or NC contacts, depending on the model
Number of outputs:	10 or 15, depending on the model
Type of output: (configurable via software parameter)	Relays with normally open contact: - RL1, RL2, RL4, RL5, RL6, RL7, RL8, RL9, RL10, RL12, RL13, RL15 Relays with changeover contact: - RL3, RL11, RL14
Maximum load:	Relays with normally open contact: 5A(250Vac) SPST 5(2)A Relays with changeover contact: 8A(250Vac) SPDT 8(3)A
Notes:	Verify the capacity of the output used. There is double insulation between the digital outputs and the low voltage of the rest of the circuit. Do not use different voltages for the various groups of relays nor within each group.

4.1.3.5 SSR Digital outputs version

Type:	Relays with NO or NC contacts, depending on the model
Number of outputs:	10 or 15, depending on the model
Type of output: (configurable via software parameter)	Relays with normally open contact: - RL1, RL2, RL4, RL5, RL6, RL7, RL8, RL9, RL10, RL11, RL12, RL13, RL14, RL15 Relays with changeover contact: - RL3
Maximum load:	Relays with normally open contact: 5A(250Vac) SPST 5(2)A Relays with changeover contact: 8A(250Vac) SPDT 8(3)A SSR relays with normally open contact 1A(12 - 250Vac): - only in AC load - minimum current is 50mA (equivalent to 12W - 250Vac) - internal impedance 300KΩ (current 0.2mA at 250Vac with an open contact)
Notes:	Verify the capacity of the output used. There is double insulation between the digital outputs and the low voltage of the rest of the circuit. Do not use different voltages for the various groups of relays nor within each group.

4.1.3.6 Wiring diagrams

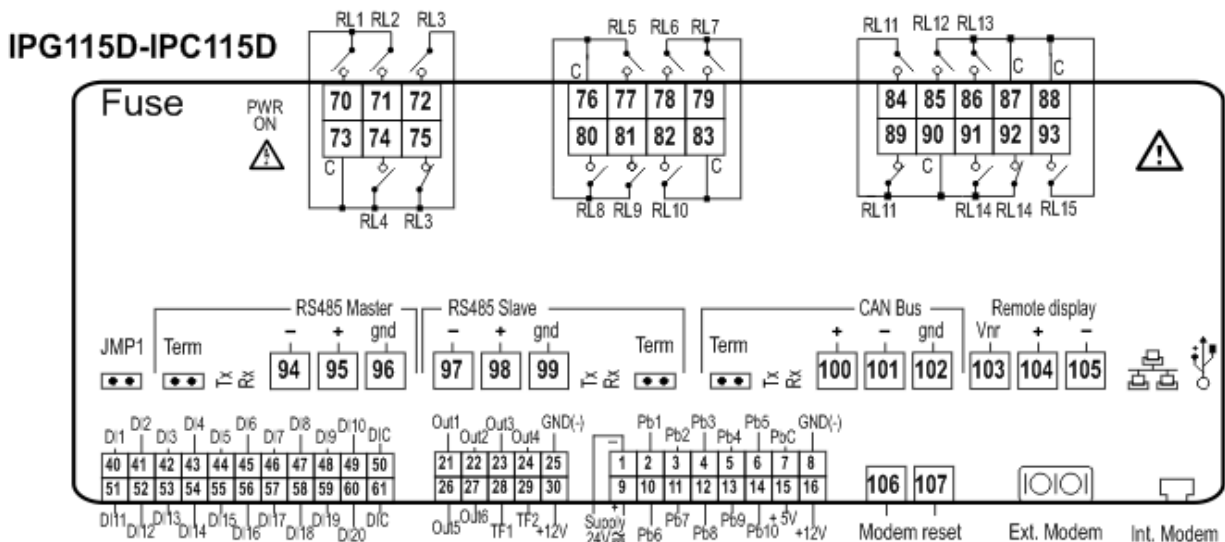

IPC115D SSR

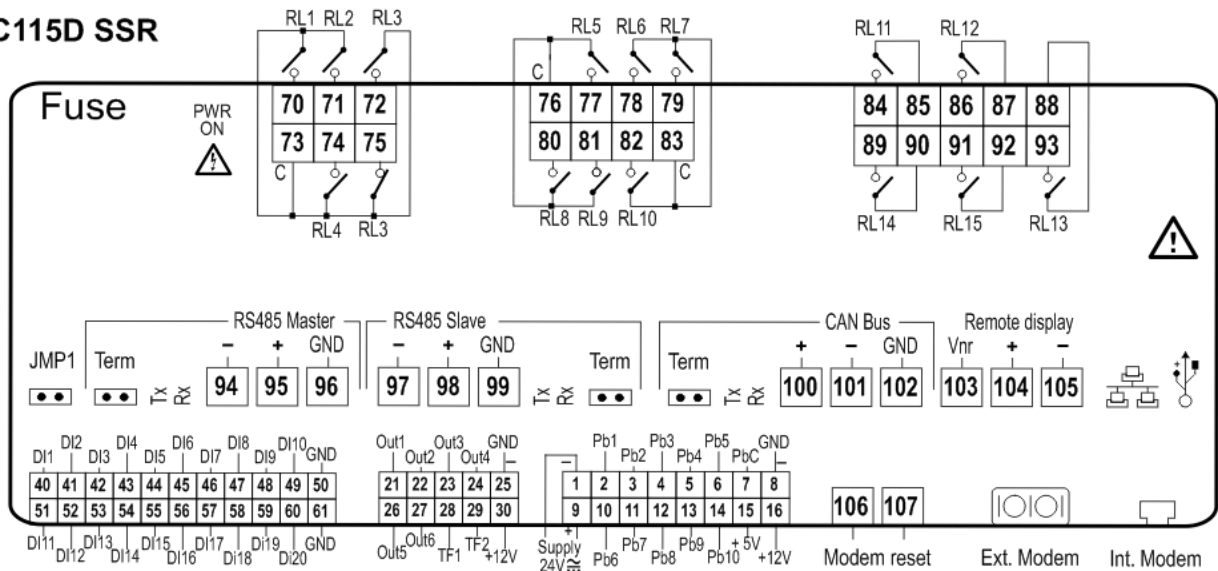

4.1.3.7 Mechanical specifications

10 DIN module

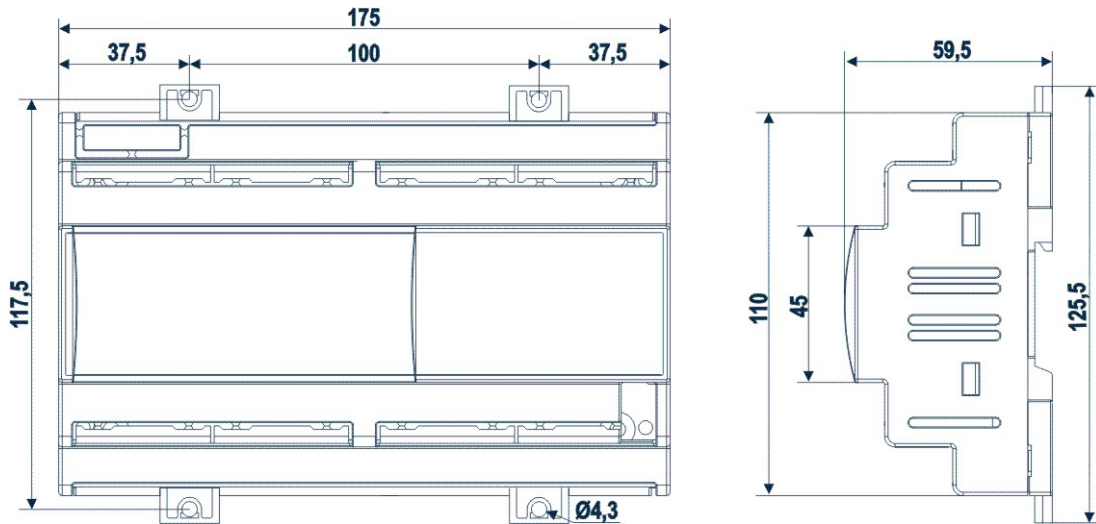

4.1.3.8 Electrical specifications

Power Supply:	24Vac +10/-15%, 50/60Hz 20 - 36Vdc
Consumption:	20VA (Vac), 15W (Vdc)
Connectors:	Molex connectors with low voltage wiring SELECOM/CIVILUX connectors for digital outputs (250Vac, 6A max)
Microprocessor:	AT91RM9200 32-bit 200Mhz
Permanent FLASH memory:	128MB, in 8-bit
RAM:	32MB or 64MB, in 16-bit
Internal clock:	standard

4.1.3.9 Plastic container

Mount:	On a DIN rail (EN 50022, DIN 43880) Fastened with screws via the removable plastic flaps.
Material:	PC-ABS Thermoplastic
Self-extinguishing:	V0 (UL94)
Comparative Tracking Index (CTI):	300V
Colour:	Black

4.1.3.10 Product certifications

Control to classify with the definitions 2.5.1 e 2.5.2 mentioned in the section 2.5 of the general requirements EN60730-1 (2.5.1 = integrated control, 2.5.2 = incorporated control).

Electrical safety:

- EN60730-1

Electromagnetic compatibility:





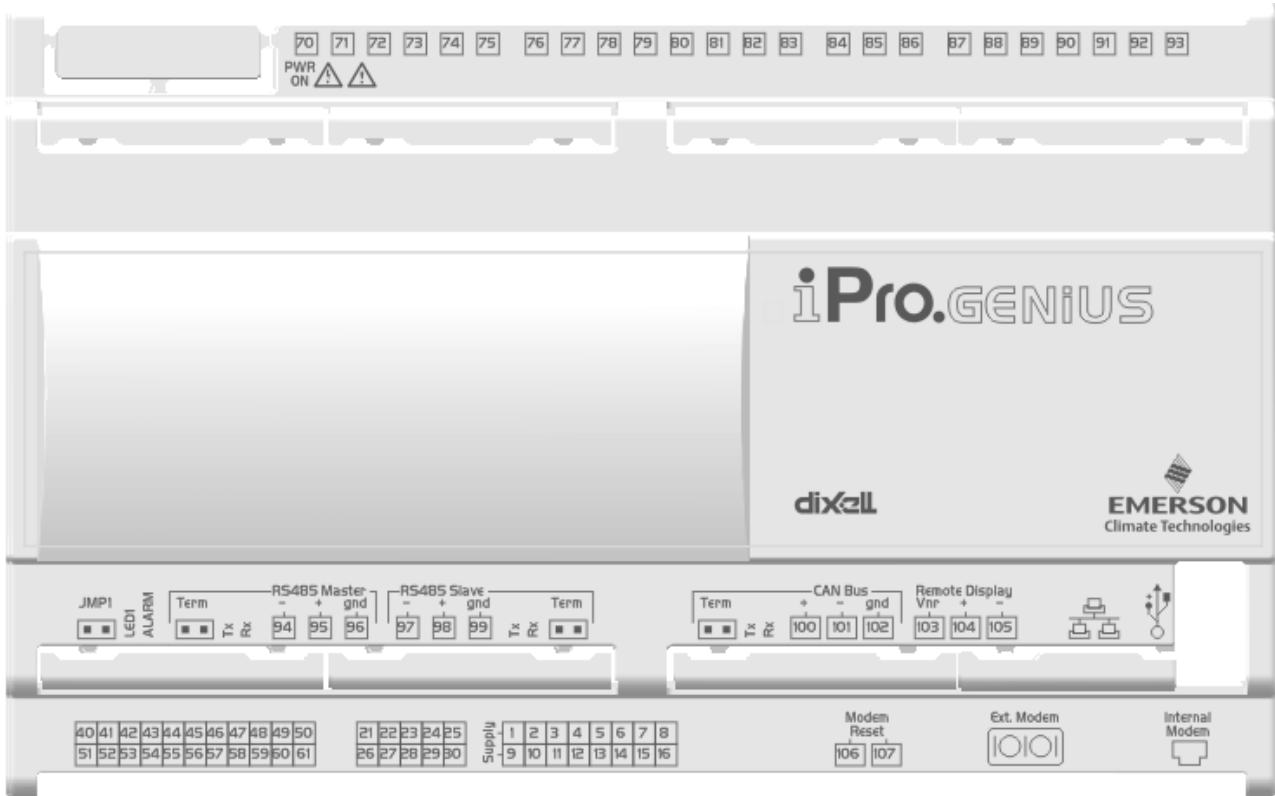



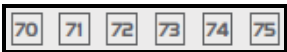

- EN61000-4-2, EN61000-4-3, EN61000-4-4, EN61000-4-5, EN61000-4-6, EN61000-4-8, EN61000-4-11

4.2 IPro.GENIUS (IPG200D RANGE)



4.2.1 Description of the connections

Connector	Description
	Connector for 24Vac/dc power supply Analogue inputs (Pb1 - Pb10, PbC) Additional power (+5Vdc, +12Vdc, GND)
	Opto-insulated analogue outputs (Out1 - Out6, GND) 24Vac/dc power supply for the opto-insulated analogue output
	Potential free opto-insulated digital inputs (DI1 - DI20, DIC) Opto-insulated 24Vac/dc digital inputs (DI1 - DI20, GND)
	USB port for downloads (BIOS, ISaGRAF® application, maps of parameters, remote display applications, network configuration, website) and uploads (log files)
	TCP/IP Ethernet port
	Connector for remote terminal (VISOGRAPH), maximum 2 terminals per iPRO.
	CANBUS connector for expansions (IPEXx0D) and drivers for electronic valves (XEVx0D) Rx and Tx LED to indicate that communication is active Line terminal (Term)
	RS485 Slave connector Rx and Tx LED to indicate that communication is active Line terminal (Term)
	RS485 Master connector Rx and Tx LED to indicate that communication is active Line terminal (Term)
	Digital relay outputs (for digital outputs with potential free contacts) 3 NO relays, 1 common

	Digital relay outputs (for digital outputs with live contacts) 3 NO relays, 1 common and 2 potential free (Neutral)
	Digital relay outputs (for digital outputs with potential free contacts) 5 NO relays, 1 common
	Digital relay outputs (for digital outputs with live contacts) 5 NO relays, 1 common and 2 potential free (Neutral)
	Digital relay outputs 2 NO relays, 1 common
	Digital relay outputs (only for 215D versions) 5 NO relays, 1 common and 1 potential free (Neutral)
	Green LED to indicate the presence of power
	Jumper to activate the RESCUE MODE
	Yellow status LEDs (LED1) and red LED (ALARM) See relative paragraph
	Connector for NC contact to reset an external modem
	RS232 connector for an external GSM modem connection (SIEMENS TC35)
	Connector for an internal analogue modem

4.2.2 Description of the inputs and outputs

Input No.	Type of Input	Description
1	Supply	Reference “-“/GND power (24Vac or 24Vdc)
2	Pb1	Configurable analogue input 1 (NTC, PTC, 0 - 20mA, 4 - 20mA, 0 - 10V, 0 - 1V, 0 - 5V, DI)
3	Pb2	Configurable analogue input 2 (NTC, PTC, 0 - 20mA, 4 - 20mA, 0 - 10V, 0 - 1V, 0 - 5V, DI)
4	Pb3	Configurable analogue input 3 (NTC, PTC, 0 - 20mA, 4 - 20mA, 0 - 10V, 0 - 1V, 0 - 5V, DI)
5	Pb4	Configurable analogue input 4 (NTC, PTC, 0 - 20mA, 4 - 20mA, 0 - 10V, 0 - 1V, 0 - 5V, DI)
6	Pb5	Configurable analogue input 5 (NTC, PTC, 0 - 20mA, 4 - 20mA, 0 - 10V, 0 - 1V, 0 - 5V, DI)
7	PbC	Common analogue inputs (NTC, PTC, DI)
8	GND(-)	Additional power reference 5Vdc and 12Vdc and analogue inputs (0 - 20mA, 4 - 20mA, 0 - 10V, 0 - 1V, 0 - 5V)
9	Supply	Reference “+“ power supply (24Vac or 24Vdc)
10	Pb6	Configurable analogue input 6 (NTC, PTC, 0 - 20mA, 4 - 20mA, 0 - 10V, 0 - 1V, 0 - 5V, DI)
11	Pb7	Configurable analogue input 7 (NTC, PTC, 0 - 20mA, 4 - 20mA, 0 - 10V, 0 - 1V, 0 - 5V, DI)
12	Pb8	Configurable analogue input 8 (NTC, PTC, 0 - 20mA, 4 - 20mA, 0 - 10V, 0 - 1V, 0 - 5V, DI)
13	Pb9	Configurable analogue input 9 (NTC, PTC, 0 - 20mA, 4 - 20mA, 0 - 10V, 0 - 1V, 0 - 5V, DI)
14	Pb10	Configurable analogue input 10 (NTC, PTC, 0 - 20mA, 4 - 20mA, 0 - 10V, 0 - 1V, 0 - 5V, DI)
15	+5V	Additional power +5Vdc
16	+12V	Additional power +12Vdc
21	Out1	Opto-insulated analogue output 1 0 - 10V
22	Out2	Opto-insulated analogue output 2 0 - 10V
23	Out3	Opto-insulated analogue output 3 0 - 10V
24	Out4	Opto-insulated analogue output 4 0 - 10V
25	GND(-)	Common opto-insulated analogue output

26	Out5	Analogue output 5 0 - 10V, 4 - 20mA, Opto-insulated relay
27	Out6	Analogue output 6 0 - 10V, 4 - 20mA, Opto-insulated relay
28	Supply	Power for opto-insulated analogue outputs at 24Vac or 24Vdc(-)
29	Supply	Power for opto-insulated analogue outputs at 24Vac or 24Vdc(+)
30	GND(-)	Common opto-insulated analogue output
40	DI1	Opto-insulated digital input 1
41	DI2	Opto-insulated digital input 2
42	DI3	Opto-insulated digital input 3
43	DI4	Opto-insulated digital input 4
44	DI5	Opto-insulated digital input 5
45	DI6	Opto-insulated digital input 6
46	DI7	Opto-insulated digital input 7
47	DI8	Opto-insulated digital input 8
48	DI9	Opto-insulated digital input 9
49	DI10	Opto-insulated digital input 10
50	GND(-)	Reference "-" for opto-insulated digital inputs 1 to 20 (if inputs 24Vac or 24Vdc)
51	DI11	Opto-insulated digital input 11
52	DI12	Opto-insulated digital input 12
53	DI13	Opto-insulated digital input 13
54	DI14	Opto-insulated digital input 14
55	DI15	Opto-insulated digital input 15
56	DI16	Opto-insulated digital input 16
57	DI17	Opto-insulated digital input 17
58	DI18	Opto-insulated digital input 18
59	DI19	Opto-insulated digital input 19
60	DI20	Opto-insulated digital input 20
61	IDC	Common opto-insulated digital inputs 1 to 20 (if potential free inputs)
70	RL1	Relay 1 normally open contact
71	C	Common relays 1, 2 and 3 (MAX 6A)
72	RL2	Relay 2 normally open contact
73	RL3	Relay 3 normally open contact
74	C	Potential free contact (MAX 6A)
75	C	Potential free contact (MAX 6A)
76	RL4	Relay 4 normally open contact
77	RL5	Relay 5 normally open contact
78	RL6	Relay 6 normally open contact
79	RL7	Relay 7 normally open contact
80	C	Common relays 4, 5, 6, 7 and 8 (MAX 6A)
81	RL8	Relay 8 normally open contact
82	C	Potential free contact (MAX 6A)
83	C	Potential free contact (MAX 6A)
84	RL9	Relay 9 normally open contact
85	RL10	Relay 10 normally open contact
86	C	Common relays 9 and 10 (MAX 6A)
87	RL11	Relay 11 normally open contact
88	RL12	Relay 12 normally open contact
89	RL13	Relay 13 normally open contact
90	C	Common relays 11, 12, 13, 14 and 15 (MAX 6A)
91	RL14	Relay 14 normally open contact
92	RL15	Relay 15 normally open contact

93	C	Potential free contact (MAX 6A)
94	RS485 Master	RS485 Master connection (-)
95	RS485 Master	RS485 Master connection (+)
96	RS485 Master	RS485 Master connection (insulated gnd)
97	RS485 Slave	RS485 Slave connection (-)
98	RS485 Slave	RS485 Slave connection (+)
99	RS485 Slave	RS485 Slave connection (insulated gnd)
100	CAN Bus	CAN Bus connection (+), not open
101	CAN Bus	CAN Bus connection (-), not open
102	CAN Bus	CAN Bus connection (insulated gnd), not open
103	Remote Display	Connection for VISOGRAPH remote terminal (Vnr)
104	Remote Display	Connection for VISOGRAPH remote terminal (+)
105	Remote Display	Connection for VISOGRAPH remote terminal (-)
106	Modem Reset	NC relay input to reset an external modem (24Vac/dc)
107	Modem Reset	NC relay output to reset an external modem (24Vac/dc)

4.2.3 Technical specifications

4.2.3.1 Analogue inputs

Analogue conversion type:	10-bit A/D converter
Number of inputs:	10
Type of analogue input: (configurable via software parameter)	NTC Dixell (-50T110°C; 10KΩ±1% at 25°C) PTC Dixell(-55T115°C; 990Ω±1% at 25°C) Digital input (potential free contact) Voltage: 0 - V, 0 - 5V, 0 - 10V (input resistance 3.7KΩ) Current: 0 - 20mA, 4 - 20mA (input resistance 100Ω)
Digital input status variation detection time:	100ms (in any case it depends on the cycle time set by the user in the given application)
Accuracy:	NTC, PTC: ±1 °C 0-1V: ±20mV 0-5V: ±100mV 0-10V:±200mV 2-20mA, 4-20mA: ±0.30mA
Additional power:	+12V: 200mA in total +5v: 100mA
Notes: 	Any inputs that are powered with a voltage that differs from that supplied by the device (+12V or +5V) must be powered separately with another transformer (do not use the same secondary of the controller's power) in order to prevent the inputs from malfunctioning or being damaged.

4.2.3.2 Digital inputs

Type: (configurable via software parameter)	Opto-insulated potential free or live contact (24Vac/dc) External power 24Vac/dc ±20%
Number of inputs:	20
Digital input status variation detection time:	100ms (in any case it depends on the cycle time set by the user in the given application)
Notes: 	If the digital inputs are used with voltage, use another transformer (do not use the same secondary of the controller's power) in order to prevent the inputs from malfunctioning or being damaged.

4.2.3.3 Analogue outputs

Type:	Opto-insulated with separate 24Vac/dc power supply
Number of outputs:	6
Type of analogue output: (configurable via software parameter)	4 fixed outputs 0-10Vdc (Out1 - Out4) 2 configurable outputs 0-10Vdc, 4-20mA (Out5 and Out6)
Maximum load:	40mA (Out1 - Out4) 20mA (Out5 and Out6) max with configured outputs 0-10Vdc 400Ω max with configured outputs 4-20Ma 22Ω per live analogue output

Accuracy:	Out1 - Out4: $\pm 2\%$ full scale Out5 - Out6: $\pm 2\%$ full scale
Resolution:	8bit
Notes:	The electrical devices controlled by these analogue outputs must be powered separately with another transformer (do not use the same secondary of the controller's power) in order to prevent the outputs from malfunctioning or being damaged.



4.2.3.4 Digital outputs

Type:	Relays with NO contacts
Number of outputs:	10 or 15, depending on the model
Type of output: (configurable via software parameter)	Relays with normally open contact
Maximum load:	5A(250Vac) SPST 5(2)A
Notes:	Verify the capacity of the output used. There is double insulation between the digital outputs and the low voltage of the rest of the circuit. Do not use different voltages for the various groups of relays nor within each group.



4.2.3.5 Wiring diagrams

IPG215D

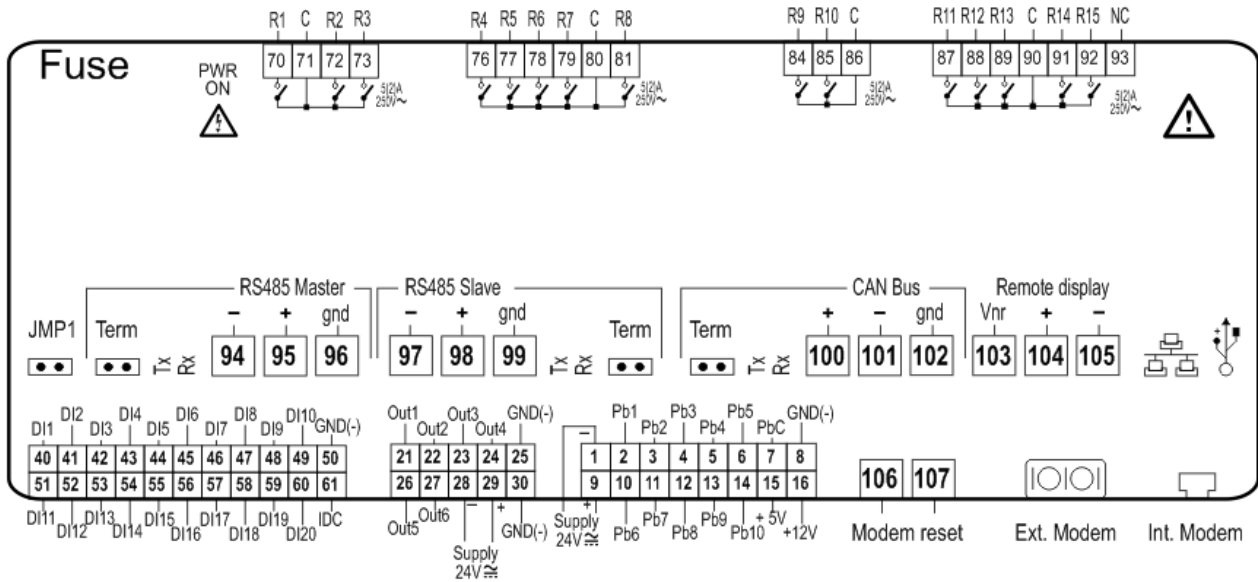

4.2.3.6 Mechanical specifications

10 DIN module

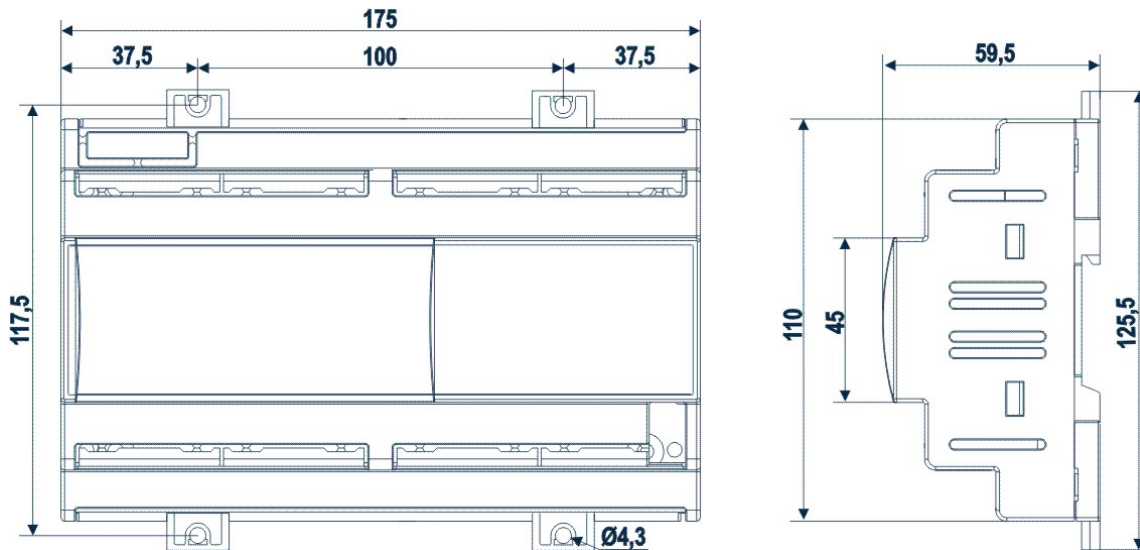

4.2.3.7 Electrical specifications

Power Supply:	24Vac +10/-15%, 50/60Hz 20 - 36Vdc
Consumption:	20VA (Vac), 15W (Vdc)
Connectors:	Phoenix quick coupling connectors for low voltage STELVIO 90° screw connectors for digital outputs (250Vac, 6A max)
Microprocessor:	AT91RM9200 32-bit 200Mhz
Permanent FLASH memory:	128MB, in 8-bit
RAM:	32MB o 64MB, in 16-bit
Internal clock:	standard

4.2.3.8 Plastic container

Mount:	On a DIN rail (EN 50022, DIN 43880) Fastened with screws via the removable plastic flaps.
Material:	PC-ABS Thermoplastic
Self-extinguishing:	V0 (UL94)
Comparative Tracking Index (CTI):	300V
Colour:	White

4.2.3.9 Product certifications

Control to classify with the definitions 2.5.1 e 2.5.2 mentioned in the section 2.5 of the general requirements EN60730-1 (2.5.1 = integrated control, 2.5.2 = incorporated control).

Electrical safety:

- EN60730-1







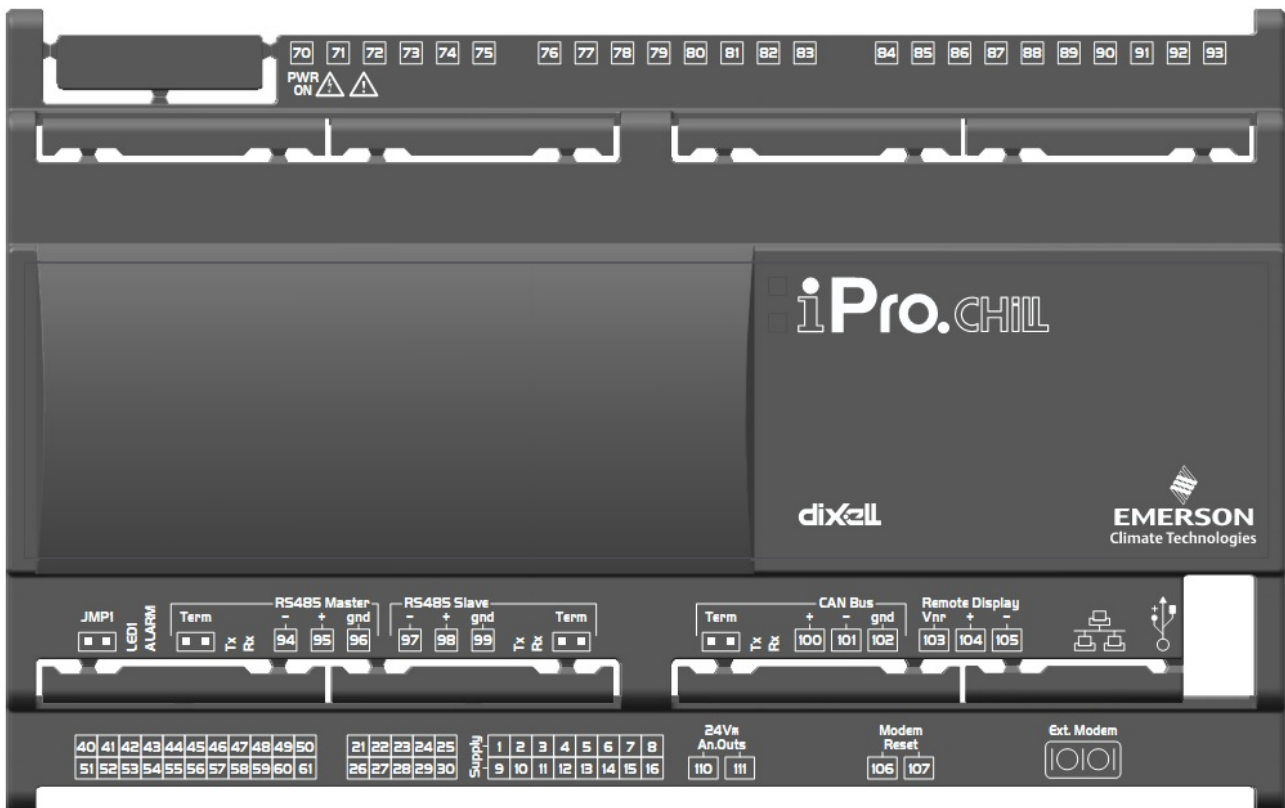
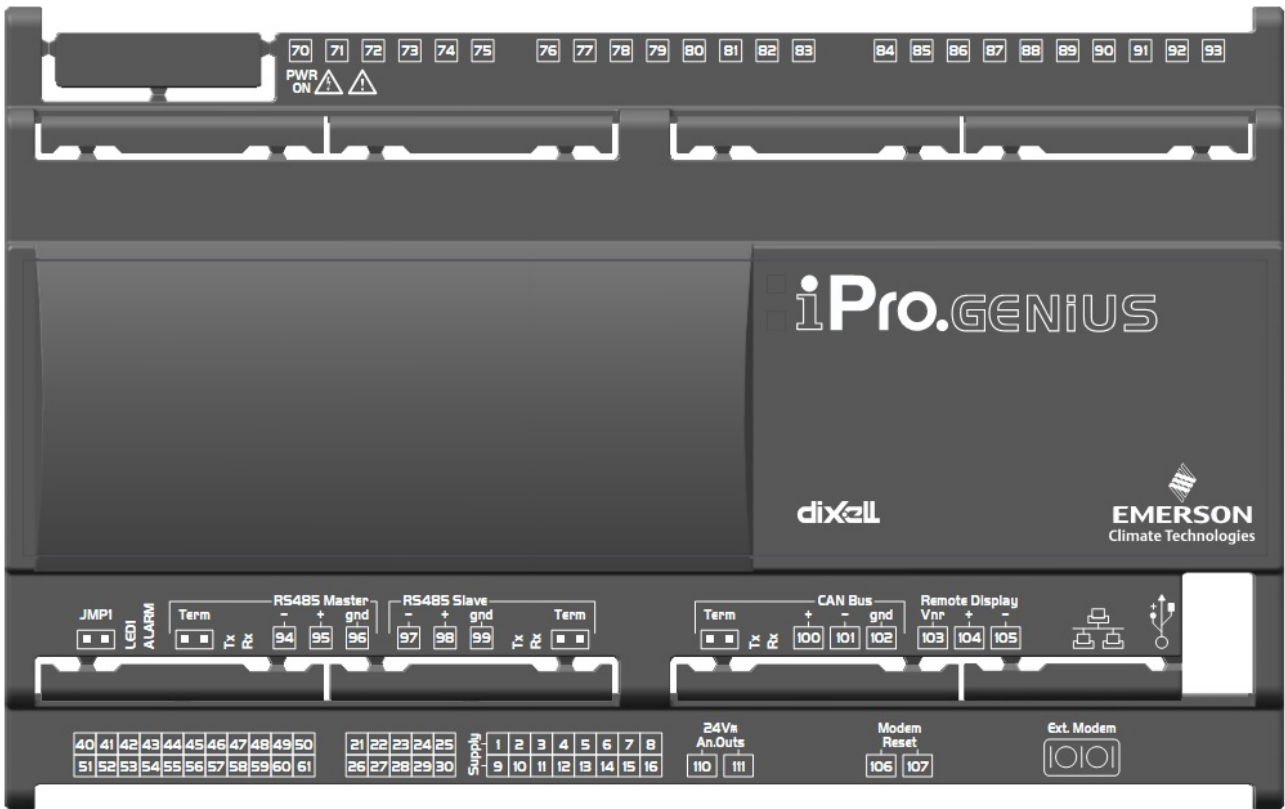









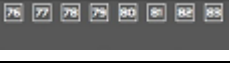

Electromagnetic compatibility:

- EN61000-4-2, EN61000-4-3, EN61000-4-4, EN61000-4-5, EN61000-4-6, EN61000-4-8, EN61000-4-11

4.3 IPRO.GENIUS AND IPRO.CHILL (IPG300D – IPC300D RANGES)



4.3.1 Description of the connections

Connector	Description
	Connector for 24Vac/dc power supply Analogue inputs (Pb1 - Pb10, PbC) Additional power (+5Vdc, +12Vdc, GND)
	Optoinsulated analogue outputs (Out1 - Out6) PWM (TF1 - T2) Additional power (+12Vdc for TF reference, GND for Out reference)
	Potential free opto-insulated digital inputs (DI1 - DI20, DIC) Opto-insulated 24Vac/dc digital inputs (DI1 - DI20, GND)
	USB port for downloads (BIOS, ISaGRAF® application, maps of parameters, remote display applications, network configuration, website) and uploads (log files)
	TCP/IP Ethernet port
	Connector for remote terminal (VISOGRAPH), maximum 2 terminals per iPRO.
	CANBUS connector for expansions (IPEXx0D) and drivers for electronic valves (XEVx0D) Rx and Tx LED to indicate that communication is active Line terminal (Term)
	RS485 Slave connector Rx and Tx LED to indicate that communication is active Line terminal (Term)
	RS485 Master connector Rx and Tx LED to indicate that communication is active Line terminal (Term)
	Digital relay outputs 4 NO relays, 2 common
	Digital relay outputs 3 NO relays, 1 common + 3 NO relays, 1 common
	Digital relay outputs 3 NO relays, 2 common + 2 NO relays, 3 common
	Green LED to indicate the presence of power
	Jumper to activate the RESCUE MODE
	Yellow status LEDs (LED1) and red LED (ALARM) See relative paragraph
	Optoinsulated analogue outputs 24Vac/dc power supply
	Connector for NC contact to reset an external modem
	RS232 connector for an external GSM modem connection (SIEMENS TC35)

4.3.2 Description of the inputs and outputs

Input No.	Type of Input	Description
1	Supply	Reference “-“/GND power (24Vac or 24Vdc)
2	Pb1	Configurable analogue input 1 (NTC, PTC, 0 - 20mA, 4 - 20mA, 0 - 10V, 0 - 1V, 0 - 5V, DI)
3	Pb2	Configurable analogue input 2 (NTC, PTC, 0 - 20mA, 4 - 20mA, 0 - 10V, 0 - 1V, 0 - 5V, DI)
4	Pb3	Configurable analogue input 3 (NTC, PTC, 0 - 20mA, 4 - 20mA, 0 - 10V, 0 - 1V, 0 - 5V, DI)
5	Pb4	Configurable analogue input 4 (NTC, PTC, 0 - 20mA, 4 - 20mA, 0 - 10V, 0 - 1V, 0 - 5V, DI)
6	Pb5	Configurable analogue input 5 (NTC, PTC, 0 - 20mA, 4 - 20mA, 0 - 10V, 0 - 1V, 0 - 5V, DI)
7	PbC	Common analogue inputs (NTC, PTC, DI)
8	GND (-)	Additional power reference 5Vdc and 12Vdc and analogue inputs (0 - 20mA, 4 - 20mA, 0 - 10V, 0 - 1V, 0 - 5V)
9	Supply	Reference “+“ power supply (24Vac or 24Vdc)
10	Pb6	Configurable analogue input 6 (NTC, PTC, 0 - 20mA, 4 - 20mA, 0 - 10V, 0 - 1V, 0 - 5V, DI)
11	Pb7	Configurable analogue input 7 (NTC, PTC, 0 - 20mA, 4 - 20mA, 0 - 10V, 0 - 1V, 0 - 5V, DI)
12	Pb8	Configurable analogue input 8 (NTC, PTC, 0 - 20mA, 4 - 20mA, 0 - 10V, 0 - 1V, 0 - 5V, DI)
13	Pb9	Configurable analogue input 9 (NTC, PTC, 0 - 20mA, 4 - 20mA, 0 - 10V, 0 - 1V, 0 - 5V, DI)
14	Pb10	Configurable analogue input 10 (NTC, PTC, 0 - 20mA, 4 - 20mA, 0 - 10V, 0 - 1V, 0 - 5V, DI)
15	+5V	Additional power +5Vdc
16	+12V	Additional power +12Vdc
21	Out1	Analogue output 1 0 - 10V
22	Out2	Analogue output 2 0 - 10V
23	Out3	Analogue output 3 0 - 10V
24	Out4	Analogue output 4 0 - 10V
25	GND(-)	Additional power reference 12Vdc and analogue outputs
26	Out5	Analogue output 5 0 - 10V, 4 - 20mA, Relay (if TF1 is not used)
27	Out6	Analogue output 6 0 - 10V, 4 - 20mA, Relay (if TF2 is not used)
28	TF1	Analogue output TF1 PWM (if Out5 is not used)
29	TF2	Analogue output TF2 PWM (if Out6 is not used)
30	+12V	Additional power +12Vdc for TF outputs
40	DI1	Opto-insulated digital input 1
41	DI2	Opto-insulated digital input 2
42	DI3	Opto-insulated digital input 3
43	DI4	Opto-insulated digital input 4
44	DI5	Opto-insulated digital input 5
45	DI6	Opto-insulated digital input 6
46	DI7	Opto-insulated digital input 7
47	DI8	Opto-insulated digital input 8
48	DI9	Opto-insulated digital input 9
49	DI10	Opto-insulated digital input 10
50	GND(-)	Reference “-“ for opto-insulated digital inputs 1 to 20 (if inputs 24Vac or 24Vdc)
51	DI11	Opto-insulated digital input 11
52	DI12	Opto-insulated digital input 12
53	DI13	Opto-insulated digital input 13
54	DI14	Opto-insulated digital input 14
55	DI15	Opto-insulated digital input 15
56	DI16	Opto-insulated digital input 16
57	DI17	Opto-insulated digital input 17
58	DI18	Opto-insulated digital input 18

59	DI19	Opto-insulated digital input 19
60	DI20	Opto-insulated digital input 20
61	IDC	Common opto-insulated digital inputs 1 to 20 (if potential free inputs)
70	RL1	Relay 1 normally open contact
71	RL2	Relay 2 normally open contact
72	RL3	Relay 3 normally open contact
73	C	Common relays 1, 2, 3 and 4
74	RL4	Relay 4 normally open contact
75	C	Common relays 1, 2, 3 and 4
76	C	Common relays 5, 8 and 9
77	RL5	Relay 5 normally open contact
78	RL6	Relay 6 normally open contact
79	RL7	Relay 7 normally open contact
80	RL8	Relay 8 normally open contact
81	RL9	Relay 9 normally open contact
82	RL10	Relay 10 normally open contact
83	C	Common relays 6, 7 and 10
84	RL11	Relay 11 normally open contact
85	RL12	Relay 12 normally open contact
86	RL13	Relay 13 normally open contact
87	C	Common relays 12, 13 and 15
88	C	Common relays 12, 13 and 15
89	C	Common relays 11 and 14
90	C	Common relays 11 and 14
91	RL14	Relay 14 normally open contact
92	C	Common relays 11 and 14
93	RL15	Relay 15 normally open contact
94	RS485 Master	RS485 Master connection (-)
95	RS485 Master	RS485 Master connection (+)
96	RS485 Master	RS485 Master connection (insulated gnd)
97	RS485 Slave	RS485 Slave connection (-)
98	RS485 Slave	RS485 Slave connection (+)
99	RS485 Slave	RS485 Slave connection (insulated gnd)
100	CAN Bus	CAN Bus connection (+), not open
101	CAN Bus	CAN Bus connection (-), not open
102	CAN Bus	CAN Bus connection (insulated gnd), not open
103	Remote Display	Connection for VISOGRAPH remote terminal (Vnr)
104	Remote Display	Connection for VISOGRAPH remote terminal (+)
105	Remote Display	Connection for VISOGRAPH remote terminal (-)
106	Modem Reset	NC relay input to reset an external modem (24Vac/dc)
107	Modem Reset	NC relay output to reset an external modem (24Vac/dc)
110	Supply	Power supply for opto-insulated analogue outputs at 24Vac or 24Vdc(+)
111	Supply	Power supply for opto-insulated analogue outputs at 24Vac or 24Vdc(-)

4.3.3 Technical specifications

4.3.3.1 Analogue inputs

Analogue conversion type:	10-bit A/D converter
Number of inputs:	10
Type of analogue input: (configurable via software parameter)	NTC Dixell (-50T110°C; 10KΩ±1% at 25°C) PTC Dixell(-55T115°C; 990Ω±1% at 25°C) Digital input (potential free contact) Voltage: 0 - V, 0 - 5V, 0 - 10V (input resistance 3.7KΩ) Current: 0 - 20mA, 4 - 20mA (input resistance 100Ω)
Digital input status variation detection time:	100ms (in any case it depends on the cycle time set by the user in the given application)
Accuracy:	NTC, PTC: ±1°C 0-1V: ±20mV 0-5V: ±100mV 0-10V: ±200mV 2-20mA, 4-20mA: ±0.30mA
Additional power:	+12V: 200mA in total (between +12V and analogue outputs) +5v: 100mA
Notes: 	Any inputs that are powered with a voltage that differs from that supplied by the device (+12V or +5V) must be powered separately with another transformer (do not use the same secondary of the controller's power) in order to prevent the inputs from malfunctioning or being damaged.

4.3.3.2 Digital inputs

Type: (configurable via software parameter)	Opto-insulated potential free or live contact (24Vac/dc) External power 24Vac/dc ±20%
Number of inputs:	20
Digital input status variation detection time:	100ms (in any case it depends on the cycle time set by the user in the given application)
Notes: 	If the digital inputs are used with voltage, use another transformer (do not use the same secondary of the controller's power) in order to prevent the inputs from malfunctioning or being damaged.

4.3.3.3 Analogue outputs

Type:	Opto-insulated with separate 24Vac/dc power supply
Number of outputs:	6
Type of analogue output: (configurable via software parameter)	4 fixed outputs 0-10Vdc (Out1 - Out4) 2 configurable outputs 0-10Vdc, 4-20mA (Out5 and Out6) 2 PWM to be used with Dixell XV modules (TF1 and TF2)
Maximum load:	40mA (Out1 - Out4) 20mA (Out5 and Out6) max with configured outputs 0-10Vdc 400Ω max with configured outputs 4-20Ma 22Ω per live analogue output
Accuracy:	Out1 - Out4: ±2% full scale Out5 - Out6: ±2% full scale
Resolution:	8bit
Notes: 	The electrical devices controlled by these analogue outputs must be powered separately with another transformer (do not use the same secondary of the controller's power) in order to prevent the outputs from malfunctioning or being damaged.

4.3.3.4 Standard Digital outputs

Type:	Relays with NO contacts
Number of outputs:	15
Type of output: (configurable via software parameter)	Relays with normally open contact: - RL1, RL2, RL3, RL4, RL5, RL6, RL7, RL8, RL9, RL10, RL11, RL12, RL13, RL14, RL15 Optional SSR relays may be mounted at the positions: - RL11, RL12, RL13, RL14, RL15
Maximum load:	Relays with normally open contact: 5A(250Vac) SPST 5(2)A
Notes: 	Verify the capacity of the output used. There is double insulation between the digital outputs and the low voltage of the rest of the circuit. Do not use different voltages for the various groups of relays nor within each group.

4.3.3.5 Wiring diagrams

IPG315D - IPC315D

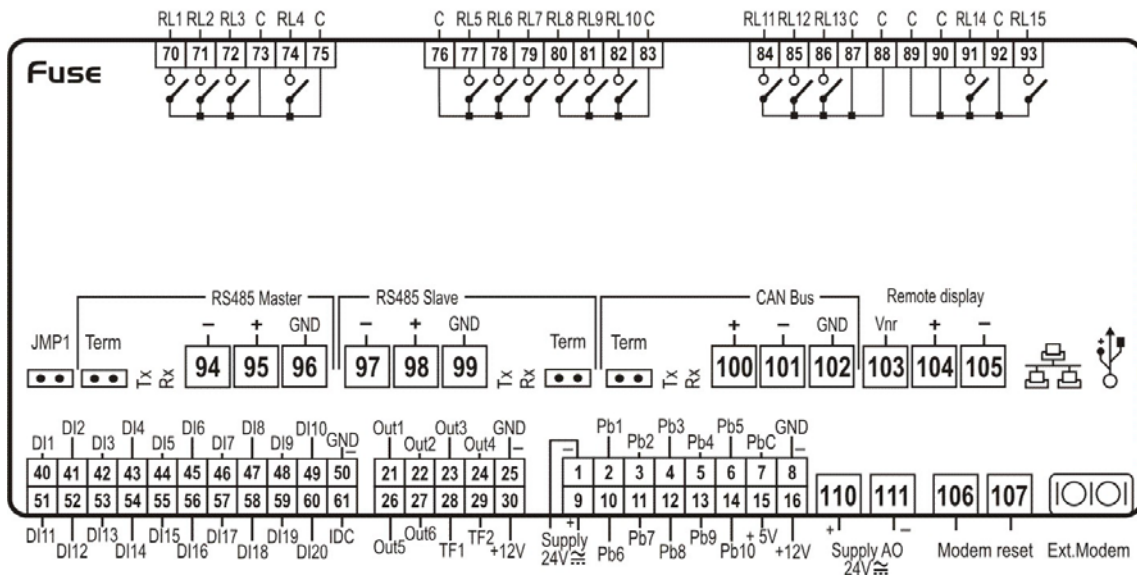

4.3.3.6 Mechanical specifications

10 DIN module

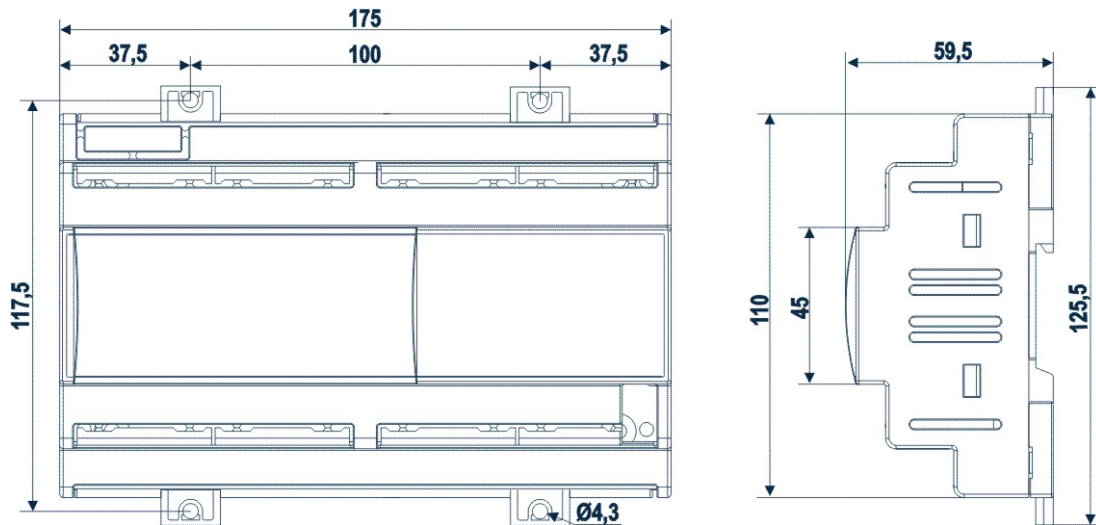

4.3.3.7 Electrical specifications

Power Supply:	24Vac +10/-15%, 50/60Hz 20 - 36Vdc
Consumption:	20VA (Vac), 15W (Vdc)
Connectors:	Molex connectors with low voltage wiring SELECOM/CIVILUX connectors for digital outputs (250Vac, 6A max)
Microprocessor:	AT91RM9200 32-bit 200Mhz
Permanent FLASH memory:	128MB, in 8-bit
RAM:	32MB or 64MB, in 16-bit
Internal clock:	standard

4.3.3.8 Plastic container

Mount:	On a DIN rail (EN 50022, DIN 43880) Fastened with screws via the removable plastic flaps.
Material:	PC-ABS Thermoplastic
Self-extinguishing:	V0 (UL94)
Comparative Tracking Index (CTI):	300V
Colour:	Black

4.3.3.9 Product certifications

Control to classify with the definitions 2.5.1 e 2.5.2 mentioned in the section 2.5 of the general requirements EN60730-1 (2.5.1 = integrated control, 2.5.2 = incorporated control).

Electrical safety:

- EN60730-1

Electromagnetic compatibility:

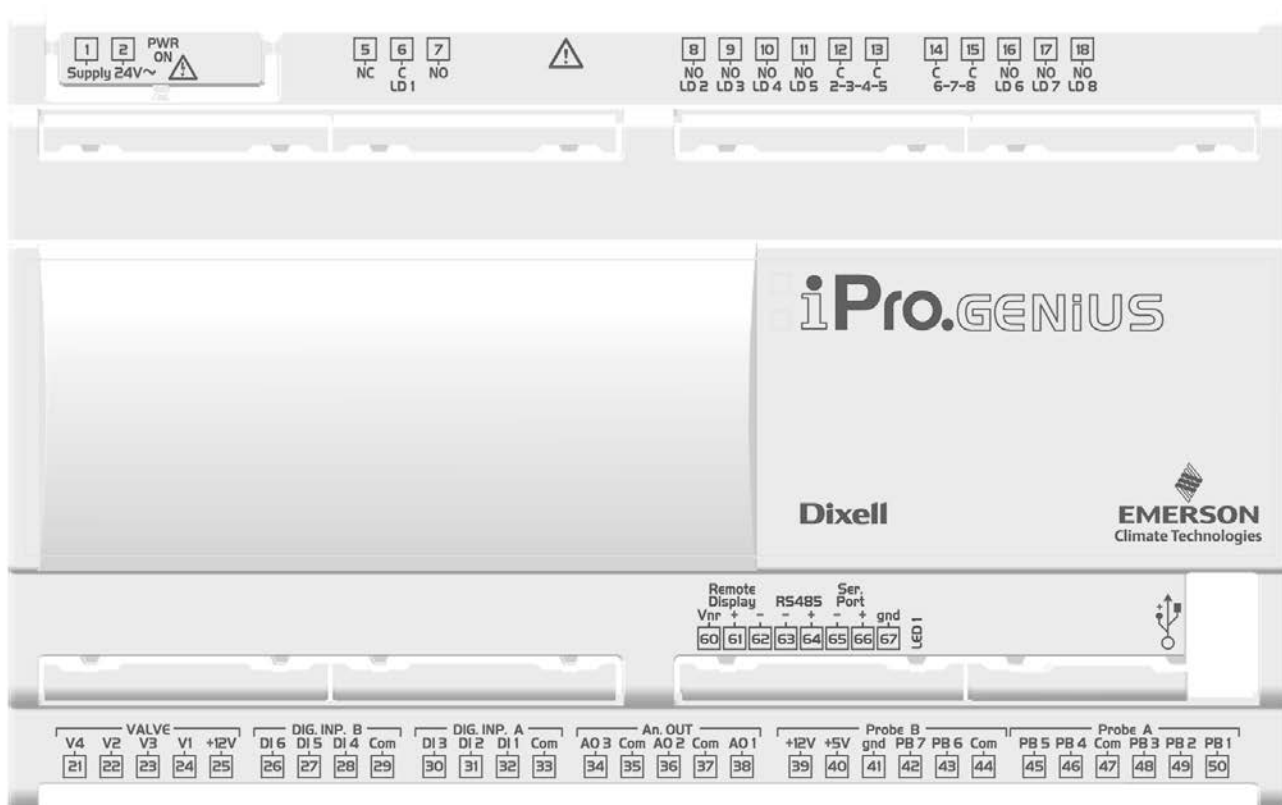

- EN61000-4-2, EN61000-4-3, EN61000-4-4, EN61000-4-5, EN61000-4-6, EN61000-4-8, EN61000-4-11

4.4 IPRO.GENIUS (IPG800D RANGES)

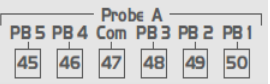
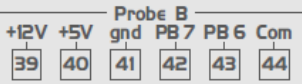

4.4.1 Description of the connections

Connector	Description
	Connector for 24Vac/dc power supply (Black color) Green LED to indicate the presence of power supply
	Connector for the Analog Outputs; depend on the model it can be: - without PWM: all the three analog output can be used as 0-10Vdc or 4-20mA - with PWM: only AO1 (38) = OUT and COM (37) = VNR while AO2 and AO3 as 0-10Vdc or 4-20mA Note: the PWM is available only if the Power Supply is 24Vac.
	Potential free not opto-insulated digital inputs. On request (different Part Number) it is possible to have the Opto-Insulated digital input but with power supply 24Vac (in this case no potential free contacts).
	USB port for downloads (BIOS, ISaGRAF® application, maps of parameters, network configuration, website) and uploads (log files) Through the adapter "USB-ETH" this port can be used as TCP/IP Ethernet port.
	Connector for remote terminal: - VISOGRAPH, maximum 2 terminals for each XB800 - VISOTOUCH, maximum 1 terminal for each XB800
	Serial Port connector; depend on the model it can be: - LAN (Dixell protocol) - RS485 MASTER (ModBus RTU)
	RS485 connector to connect the device with a monitoring system - RS485 SLAVE (ModBus RTU)
	Ground connection for RS485 and Serial Port LED1= yellow status led

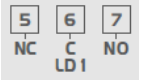
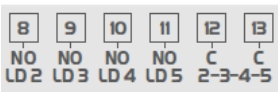
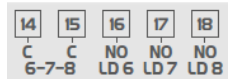
	Analog Input connector. PB1, PB2, PB3, PB4, PB5 = NTC, PTC, DI or PT1000
	Analog Input connector. PB6, PB7 = NTC, PTC, 0..20mA, 4..20mA, 0..10V, 0..1V, 0..5V, DI, PT1000
	Connector for Unipolar Valve
	Connector for Relay 1 - 16A changeover
	Connector for Relay 2, 3, 4, 5 - Relay 2 = 8A or 1A/240V SSR (NO) - Relay 3 = 8A or 1A/240V SSR (NO) - Relay 4 = 8A (NO) - Relay 5 = 8A or 16A or 16A inrush (NO)
	Connector for Relay 6, 7, 8 Relay 6 = 16A Relay 7 = 8A or 16A Relay 8 = 8A or 16A

4.4.2 Description of the inputs and outputs

Input No.	Type of Input	Description
1	Supply 24Vac	Power supply (Reference "+" for 24Vdc)
2	Supply 24Vac	Power supply (Reference "-" for 24Vdc)
5	LD1-NC	Relay 1 NC contact
6	LD1-C	Common relay 1 (MAX 12A)
7	LD1-NO	Relay 1 NO contact
8	LD2-NO	Relay 2 NO contact
9	LD3-NO	Relay 3 NO contact
10	LD4-NO	Relay 4 NO contact
11	LD5-NO	Relay 5 NO contact
12	2-3-4-5 C	Common relay 2-3-4-5 (MAX 12A)
13	2-3-4-5 C	Common relay 2-3-4-5 (MAX 12A)
14	6-7-8 C	Common relay 6-7-8 (MAX 12A)
15	6-7-8 C	Common relay 6-7-8 (MAX 12A)
16	LD6-NO	Relay 6 NO contact
17	LD7-NO	Relay 7 NO contact
18	LD8-NO	Relay 8 NO contact
21	V4 VALVE	Unipolar valve output
22	V2 VALVE	Unipolar valve output
23	V3 VALVE	Unipolar valve output
24	V1 VALVE	Unipolar valve output
25	+12V VALVE	Unipolar valve output (Common)
26	DI 6	Not Opto-insulated digital input 6 potential free contact
27	DI 5	Not Opto-insulated digital input 5 potential free contact
28	DI 4	Not Opto-insulated digital input 4 potential free contact
29	Com	Common not opto-insulated digital inputs 4 to 6
30	DI 3	Not Opto-insulated digital input 3 potential free contact
31	DI 2	Not Opto-insulated digital input 2 potential free contact
32	DI 1	Not Opto-insulated digital input 1 potential free contact
33	Com	Common not opto-insulated digital inputs 1 to 3

34	AO 3	Analogue output 3 0-10Vdc, 4-20mA
35	Com	Analogue output 2-3 common/GND
36	AO 2	Analogue output 2 0-10Vdc, 4-20mA
37	Com	Analogue output 1 common/GND (if PWM = VNR)
38	AO 1	Analogue output 1 0-10Vdc, 4-20mA, PWM (<i>if PWM=OUT and 24Vac Power supply</i>)
39	+12V	Additional power +12Vdc (output)
40	+5V	Additional power +5Vdc (output)
41	gnd	GND reference for 5Vdc/12Vdc and analogue inputs (0-20mA, 4-20mA, 0-10Vdc, 0-1Vdc, 0-5Vdc)
42	PB 7	Configurable analogue input 7 (NTC, PTC, 0..20mA, 4..20mA, 0..10V, 0..1V, 0..5V, DI, PT1000)
43	PB 6	Configurable analogue input 6 (NTC, PTC, 0..20mA, 4..20mA, 0..10V, 0..1V, 0..5V, DI, PT1000)
44	Com	Probes common (NTC, PTC, PT1000, DI)
45	PB 5	Configurable analogue input 5 (NTC, PTC, DI, PT1000)
46	PB 4	Configurable analogue input 4 (NTC, PTC, DI, PT1000)
47	Com	Probes common (NTC, PTC, PT1000, DI)
48	PB 3	Configurable analogue input 3 (NTC, PTC, DI, PT1000)
49	PB 2	Configurable analogue input 2 (NTC, PTC, DI, PT1000)
50	PB1	Configurable analogue input 1 (NTC, PTC, DI, PT1000)
60	Remote Display Vnr	Connection for VISOGRAPH-VISOTOUCH remote terminal (Vnr)
61	Remote Display +	Connection for VISOGRAPH-VISOTOUCH remote terminal (+)
62	Remote Display -	Connection for VISOGRAPH-VISOTOUCH remote terminal (-)
63	RS485 -	RS485 Slave connection (-)
64	RS485 +	RS485 Slave connection (+)
65	Ser. Port -	Serial Port connection (-) / depend on the model it can be LAN or RS485 MASTER
66	Ser. Port +	Serial Port connection (+) / depend on the model it can be LAN or RS485 MASTER
67	gnd	Ground reference for RS485 and Ser. Port

4.4.3 Technical specifications

4.4.3.1 Analogue inputs

Analogue conversion type:	10-bit A/D converter
Number of inputs:	7
Type of analogue input: (configurable via software parameter)	NTC Dixell (-50T110°C; 10KΩ±1% at 25°C) PTC Dixell(-55T115°C; 990Ω±1% at 25°C) PT1000 Dixell (-100T150°C; 1000Ω±1% at 0°C) Digital input (potential free contact) Voltage: 0-1V, 0-5V, 0-10V (input resistance 3.7KΩ) Current: 0-20mA, 4-20mA (input resistance 100Ω)
Digital input status variation detection time:	100ms (in any case it depends on the cycle time set by the user in the given application)
Accuracy:	NTC, PTC, PT1000: ±1% 0-1V: ±20mV 0-5V: ±100mV 0-10V:±200mV 0-20mA, 4-20mA: ±0.30mA
Additional power:	+12V: 100mA in total (between +12V and analogue outputs) +5V: 10mA
Notes: 	Any inputs that are powered with a voltage that differs from that supplied by the device (+12V or +5V) must be powered separately with another transformer (do not use the same secondary of the controller's power) in order to prevent the inputs from malfunctioning or being damaged.

4.4.3.2 Digital inputs

Type: (configurable via software parameter)	Not Opto-insulated free voltage contacts <i>On request (different Part Number) it is possible to have the Opto-Insulated digital input but with power supply 24Vac (in this case no potential free contacts).</i>
Number of inputs:	6
Digital input status variation detection time:	100ms (in any case it depends on the cycle time set by the user in the given application)

4.4.3.3 Analogue outputs

Type:	Non opto-insulated internal power
Number of outputs:	3
Type of analogue output: (configurable via software parameter)	2 configurable outputs 0-10Vdc 4-20mA (AO3 – AO2) 1 configurable outputs 0-10Vdc 4-20mA or PWM (AO1) <i>Note: the PWM is available only if the Power Supply is 24Vac.</i>
Maximum load:	40mA (AO1, AO2, AO3) max with configured outputs 0-10Vdc 400Ω max with configured outputs 4-20mA 22Ω per live analogue output
Accuracy:	AO1-AO2-AO3: ±2% full scale
Resolution:	8bit
Notes:	The electrical devices controlled by these analogue outputs must be powered separately with another transformer (do not use the same secondary of the controller's power) in order to prevent the outputs from malfunctioning or being damaged.

4.4.3.4 Digital outputs

Type:	Relays with NO contacts
Number of outputs:	8
Type of output: (configurable via software parameter)	Relays with normally open contact (except LD1 that is normally closed)
Maximum load:	Depend on the configuration 8A, 16A and 1A/240Vac for SSR version
Notes:	Verify the capacity of the output used. There is double insulation between the digital outputs and the low voltage of the rest of the circuit. Do not use different voltages for the various groups of relays or within each group.



4.4.3.5 Wiring diagrams

IPG808D

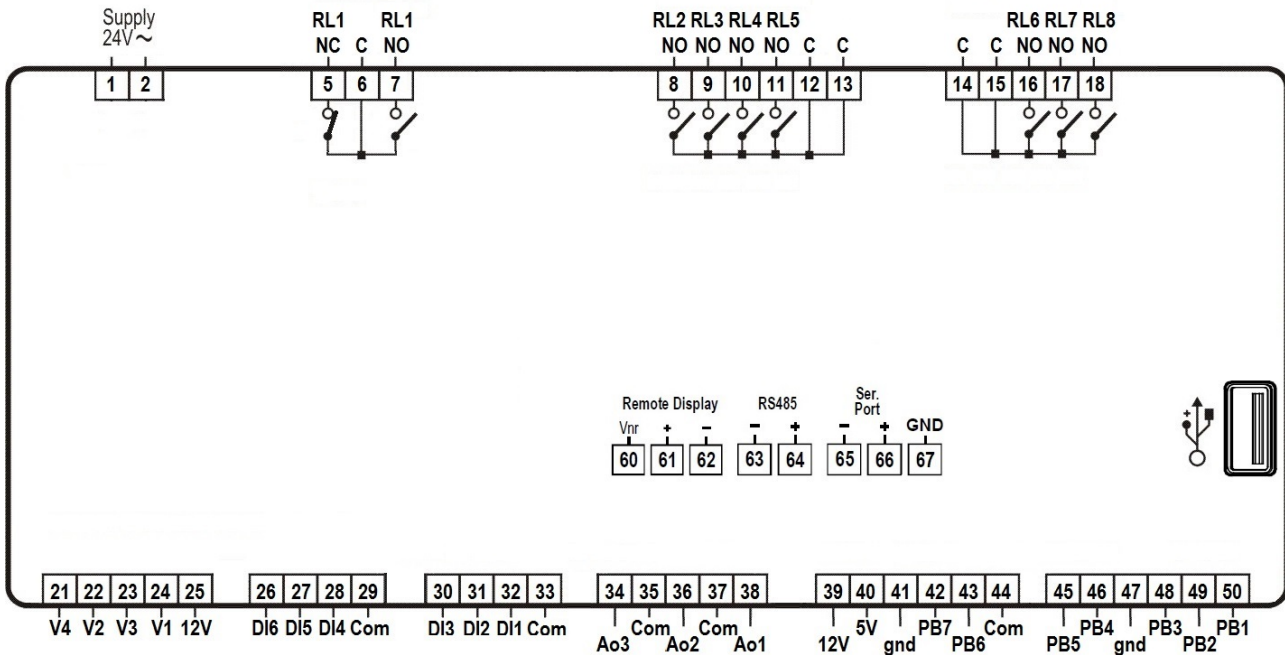

4.4.3.6 Mechanical specifications

10 DIN module

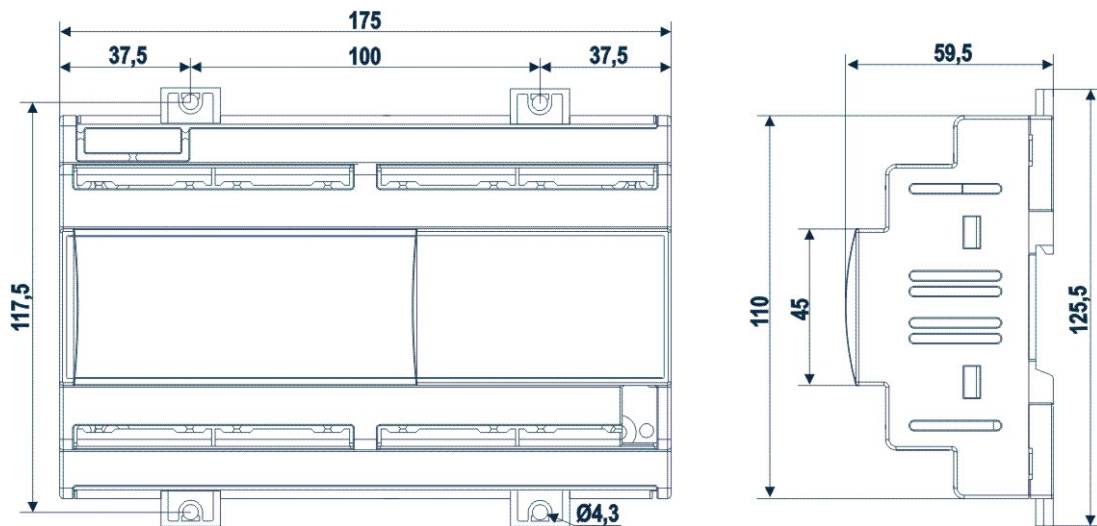

4.4.3.7 Electrical specifications

Power Supply:	24Vac +10/-15%, 50/60Hz 20 - 36Vdc
Consumption:	20VA (Vac), 15W (Vdc)
Connectors:	Molex connectors with low voltage wiring SELECOM/CIVILUX connectors for digital outputs (250Vac, 6A max)
Microprocessor:	AT91RM9200 32-bit 200Mhz
Permanent FLASH memory:	128MB, in 8-bit
RAM:	32MB or 64MB, in 16-bit
Internal clock:	standard

4.4.3.8 Plastic container

Mount:	On a DIN rail (EN 50022, DIN 43880) Fastened with screws via the removable plastic flaps.
Material:	PC-ABS Thermoplastic
Self-extinguishing:	V0 (UL94)
Comparative Tracking Index (CTI):	300V
Colour:	Black

4.4.3.9 Product certifications

Control to classify with the definitions 2.5.1 e 2.5.2 mentioned in the section 2.5 of the general requirements EN60730-1 (2.5.1 = integrated control, 2.5.2 = incorporated control).

Electrical safety:

- EN60730-1

Electromagnetic compatibility:

- EN61000-4-2, EN61000-4-3, EN61000-4-4, EN61000-4-5, EN61000-4-6, EN61000-4-8, EN61000-4-11

4.5 IPRO 4 DIN (IPG100D – IPG200D – IPC100E RANGES)

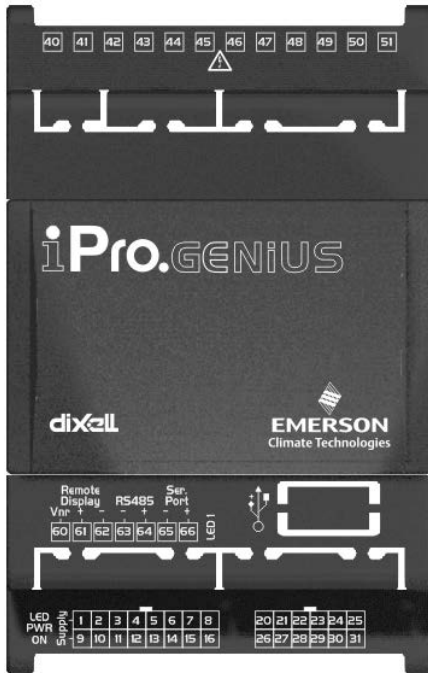

4.5.1 Description of the connections

Connector	Description
	Connector for 24Vac/dc power supply Analogue inputs (Pb1 - Pb6, PbC) Additional power (+5Vdc, +12Vdc, GND) Analogue outputs (Out1 - Out4, GND)
	24Vac/dc digital inputs (DI1 - DI11, GND)
	Connector for remote terminal (VISOGRAPH), maximum 1 terminal per iPRO. RS485 Slave connector Serial port connector (LAN or RS485)
	USB port for downloads (BIOS, ISaGRAF® application, maps of parameters, remote display applications, network configuration, website) and uploads (log files) Connection with the computer via a USB-ETH converter
	Digital relay outputs 4 NO relays, 2 common
	Digital relay outputs 4 NO relays, 2 common

4.5.2 Description of the inputs and outputs

Input No.	Type of Input	Description
1	Supply	Reference “-“/GND power (24Vac or 24Vdc)
2	Pb1	Configurable analogue input 1 (NTC, PTC, 0 - 20mA, 4 - 20mA, 0 - 10V, 0 - 1V, 0 - 5V, DI)
3	Pb2	Configurable analogue input 2 (NTC, PTC, 0 - 20mA, 4 - 20mA, 0 - 10V, 0 - 1V, 0 - 5V, DI)
4	Pb3	Configurable analogue input 3 (NTC, PTC, 0 - 20mA, 4 - 20mA, 0 - 10V, 0 - 1V, 0 - 5V, DI)
5	+12V	Additional power +12Vdc
6	+5V	Additional power +5Vdc
7	Out1	Analogue output 1 0 - 10V, 4 - 20mA, Relay
8	Out2	Analogue output 2 0 - 10V, 4 - 20mA, Relay
9	Supply	Reference “+“ power supply (24Vac or 24Vdc)
10	Pb4	Configurable analogue input 4 (NTC, PTC, 0 - 20mA, 4 - 20mA, 0 - 10V, 0 - 1V, 0 - 5V, DI)
11	Pb5	Configurable analogue input 5 (NTC, PTC, 0 - 20mA, 4 - 20mA, 0 - 10V, 0 - 1V, 0 - 5V, DI)
12	Pb6	Configurable analogue input 6 (NTC, PTC, 0 - 20mA, 4 - 20mA, 0 - 10V, 0 - 1V, 0 - 5V, DI)
13	PbC	Common analogue inputs (NTC, PTC, DI)
14	GND(-)	Additional power reference 5Vdc and 12Vdc, analogue inputs (0 - 20mA, 4 - 20mA, 0 - 10V, 0 - 1V, 0 - 5V), analogue outputs
15	Out3	Analogue output 3 0 - 10V, 4 - 20mA, Relay
16	Out4	Analogue output 4 0 - 10V, 4 - 20mA, Relay
20	DI1	Digital input 1 24Vac/dc
21	DI2	Digital input 2 24Vac/dc
22	DI3	Digital input 3 24Vac/dc
23	DI4	Digital input 4 24Vac/dc
24	DI5	Digital input 5 24Vac/dc
25	DI6	Digital input 6 24Vac/dc
26	DI7	Digital input 7 24Vac/dc
27	DI8	Digital input 8 24Vac/dc
28	DI9	Digital input 9 24Vac/dc
29	DI10	Digital input 10 24Vac/dc

30	DI11	Digital input 11 24Vac/dc
31	GND(-)	Reference “-“ for digital inputs from 1 to 11 (if version with dry contacts, this input has to be used only as common for the digital inputs)
40	C	Common relays 1, 2, 3 and 4 (MAX 10A)
41	C	Common relays 1, 2, 3 and 4 (MAX 10A)
42	RL1	Relay 1 normally open contact
43	RL2	Relay 2 normally open contact
44	RL3	Relay 3 normally open contact
45	RL4	Relay 4 normally open contact
46	RL5	Relay 5 normally open contact
47	C	Common relays 5, 6, 7 and 8 (MAX 10A)
48	C	Common relays 5, 6, 7 and 8 (MAX 10A)
49	RL6	Relay 6 normally open contact
50	RL7	Relay 7 normally open contact
51	RL8	Relay 8 normally open contact
60	Remote Display	Connection for VISOGRAPH remote terminal (Vnr)
61	Remote Display	Connection for VISOGRAPH remote terminal (+)
62	Remote Display	Connection for VISOGRAPH remote terminal (-)
63	RS485 Slave	RS485 Slave connection (-)
64	RS485 Slave	RS485 Slave connection (+)
65	LAN	LAN Connection (-)
66	LAN	LAN Connection (+)

4.5.3 Technical specifications

4.5.3.1 Analogue inputs

Analogue conversion type:	10-bit A/D converter
Number of inputs:	6
Type of analogue input: (configurable via software parameter)	NTC Dixell (-50T110°C; 10KΩ±1% at 25°C) PTC Dixell(-55T115°C; 990Ω±1% at 25°C) Digital input (potential free contact) Voltage: 0 - V, 0 - 5V, 0 - 10V (input resistance 3.7KΩ) Current: 0 - 20mA, 4 - 20mA (input resistance 100Ω)
Digital input status variation detection time:	100ms (in any case it depends on the cycle time set by the user in the given application)
Accuracy:	NTC, PTC: ±1 °C 0-1V: ±20mV 0-5V: ±100mV 0-10V:±200mV 2-20mA, 4-20mA: ±0.30mA
Additional power:	+12V: 200mA in total (between +12V and analogue outputs) +5v: 100mA
Notes: 	Any inputs that are powered with a voltage that differs from that supplied by the device (+12V or +5V) must be powered separately with another transformer (do not use the same secondary of the controller's power) in order to prevent the inputs from malfunctioning or being damaged.

4.5.3.2 Digital inputs

Type: (configurable via software parameter)	Opto-insulated live contact (24Vac/dc) External power 24Vac/dc ±20%
Number of inputs:	11
Digital input status variation detection time:	100ms (in any case it depends on the cycle time set by the user in the given application)
Notes: 	Use another transformer (do not use the same secondary of the controller's power) in order to prevent the inputs from malfunctioning or being damaged.

Note: the digital inputs as dry contacts are available on request.

4.5.3.3 Analogue outputs

Type:	Non opto-insulated internal power
Number of outputs:	4
Type of analogue output: (configurable via software parameter)	4 configurable outputs 0-10Vdc 4-20mA (Out1 - Out4)
Maximum load:	40mA (Out1 - Out4) max with configured outputs 0-10Vdc 400Ω max with configured outputs 4-20mA 22Ω per live analogue output
Accuracy:	Out1 - Out4: ±2% full scale
Resolution:	8bit
Notes:	The electrical devices controlled by these analogue outputs must be powered separately with another transformer (do not use the same secondary of the controller's power) in order to prevent the outputs from malfunctioning or being damaged.

4.5.3.4 Digital outputs

Type:	Relays with NO contacts
Number of outputs:	8
Type of output: (configurable via software parameter)	Relays with normally open contact
Maximum load:	5A(250Vac) SPST 5(2)A
Notes:	Verify the capacity of the output used. There is double insulation between the digital outputs and the low voltage of the rest of the circuit. Do not use different voltages for the various groups of relays nor within each group.

4.5.3.5 Wiring diagrams

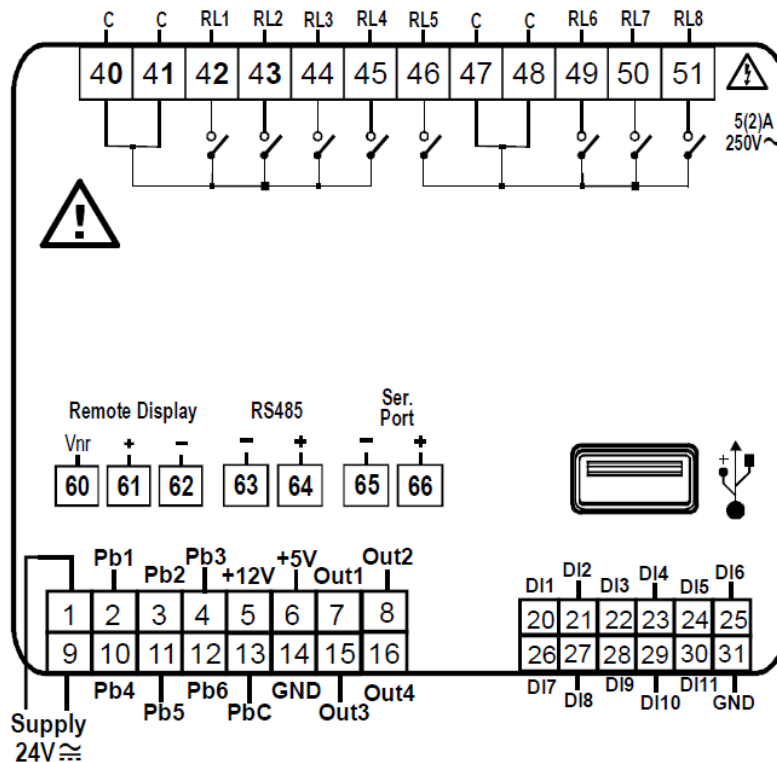

Version Rs485 Slave + LAN

Version Rs485 Slave + RS485 Master

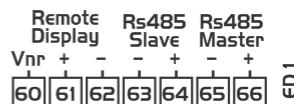

4.5.3.6 Mechanical specifications

4 DIN module

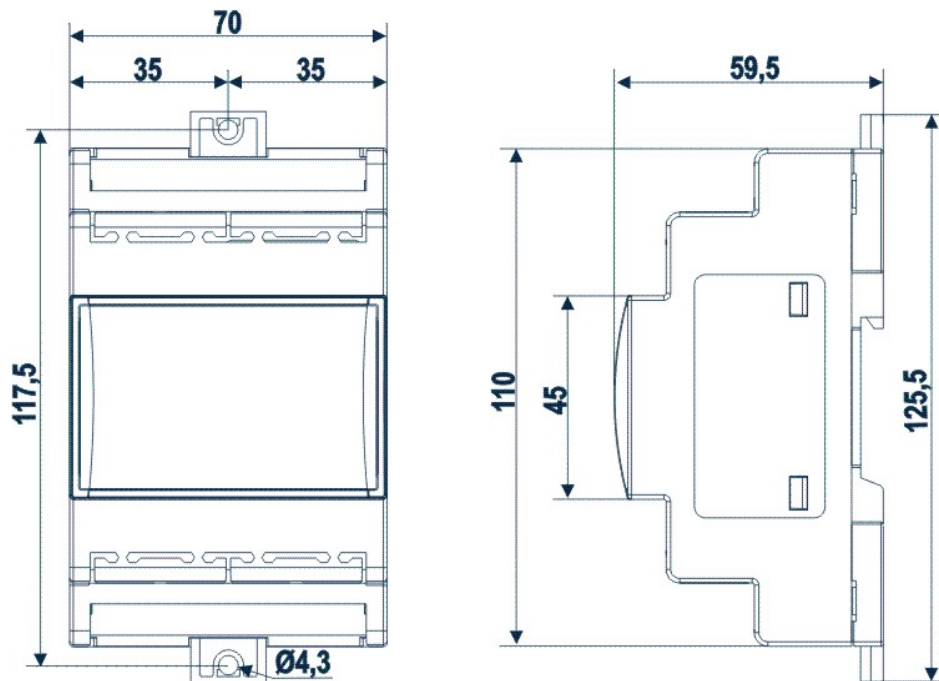

4.5.3.7 Electrical specifications

Power Supply:	24Vac +10/-15%, 50/60Hz 20 - 36Vdc
Consumption:	from 30VA (Vac), from 25W (Vdc)
Connectors:	Molex connectors with low voltage wiring (for IPG100D) Phoenix quick coupling connectors for low voltage (for IPG200D) STELVIO 90° screw connectors for digital outputs (250Vac, 6A max)
Microprocessor:	AT91SAM9260 32-bit 200Mhz
Permanent FLASH memory:	32MB, in 8-bit
RAM:	32MB, in 16
Internal clock:	standard

4.5.3.8 Plastic container

Mount:	On a DIN rail (EN 50022, DIN 43880) Fastened with screws via the removable plastic flaps.
Material:	PC-ABS Thermoplastic
Self-extinguishing:	V0 (UL94)
Comparative Tracking Index (CTI):	300V
Colour:	Black or White, depending on the model

4.5.3.9 USB-ETHERNET Adapter (Dixell specification)





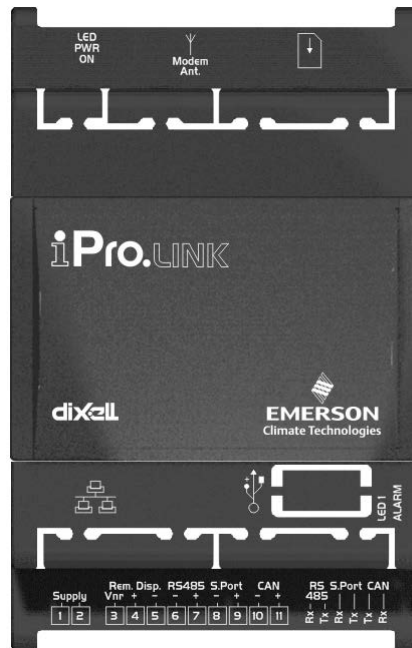

The 4 DIN range of programmable controllers can be connected to a computer via an external adapter. This adapter must be used in the processing environment for the application download in the ipro. This adapter is not set up for fixed or continuous connection. If the adapter should be kept connected continuously, the room temperature must not exceed 50°C.



4.6 IPRO.LINK (IPL500D)



4.6.1 Description of the connections

Connector	Description
	Connector for 24Vac/dc power supply
	Connector for remote terminal (VISOGRAF), maximum 1 terminal per iPRO. RS485 Slave connector Serial port connector (LAN or RS485) CANBUS connector (for expansion and driver for electroni expansion valve) Communication leds
	USB port for downloads (BIOS, ISaGRAF® application, maps of parameters, remote display applications, network configuration, website) and uploads (log files)
	Ethernet port for TCP/IP connections
	SIM CARD slot (only for version with GPRS modem)
	Connection for GPRS modem antenna

4.6.2 Description of the inputs and outputs

Input No.	Type of Input	Description
1	Supply	Reference “-“/GND power (24Vac or 24Vdc)
2	Supply	Reference “+“ power supply (24Vac or 24Vdc)
3	Remote Display	Connection for VISOGRAPH remote terminal (Vnr)
4	Remote Display	Connection for VISOGRAPH remote terminal (+)
5	Remote Display	Connection for VISOGRAPH remote terminal (-)
6	RS485 Slave	RS485 Slave connection (-)
7	RS485 Slave	RS485 Slave connection (+)
8	Serial Port	LAN or RS485 MASTER Connection (-) – depend on the model
9	Serial Port	LAN or RS485 MASTER Connection (+) – depend on the model
10	CAN	CANBUS connection (-)
11	CAN	CANBUS connection (+)

4.6.3 Technical specifications

4.6.3.1 Wiring diagrams

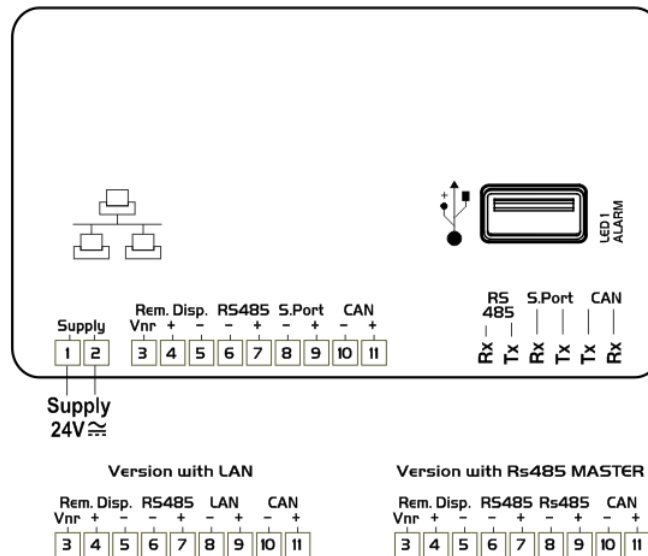

4.6.3.2 Mechanical specifications

4 DIN module

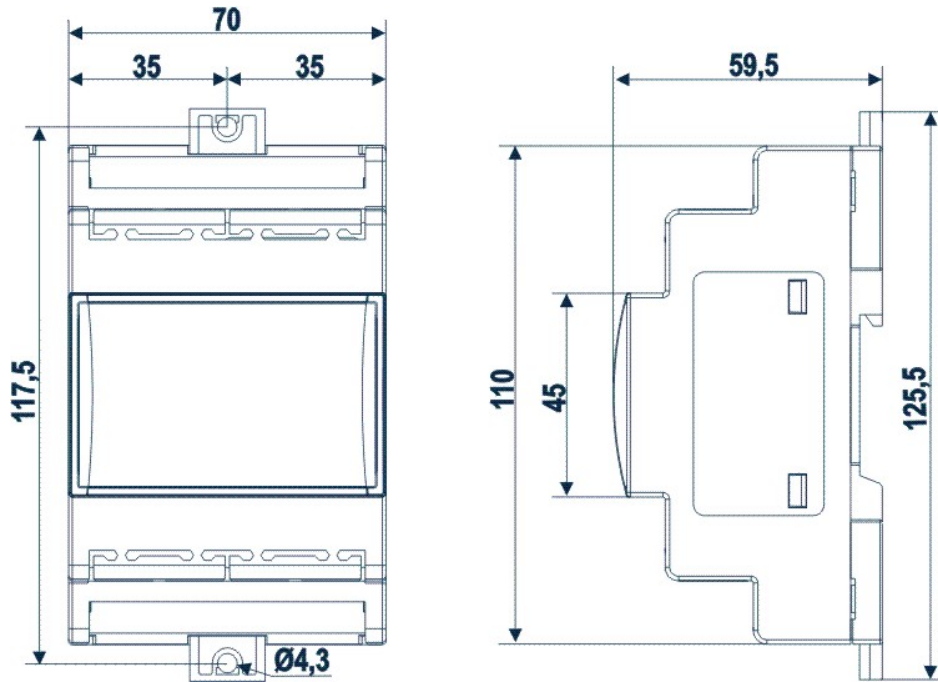

4.6.3.3 Electrical specifications

Power Supply:	24Vac +10/-15%, 50/60Hz 20 - 36Vdc
Consumption:	from 20VA (Vac), from 15W (Vdc)
Connectors:	STELVIO 90° screw connectors for digital outputs (250Vac, 6A max)
Microprocessor:	AT91SAM9260 32-bit 200Mhz
Permanent FLASH memory:	128MB, in 8
RAM:	32MB, in 16
Internal clock:	standard

4.6.3.4 Plastic container

Mount:	On a DIN rail (EN 50022, DIN 43880) Fastened with screws via the removable plastic flaps.
Material:	PC-ABS Thermoplastic
Self-extinguishing:	V0 (UL94)
Comparative Tracking Index (CTI):	300V
Colour:	Black or White, depending on the model

4.7 IPX106D

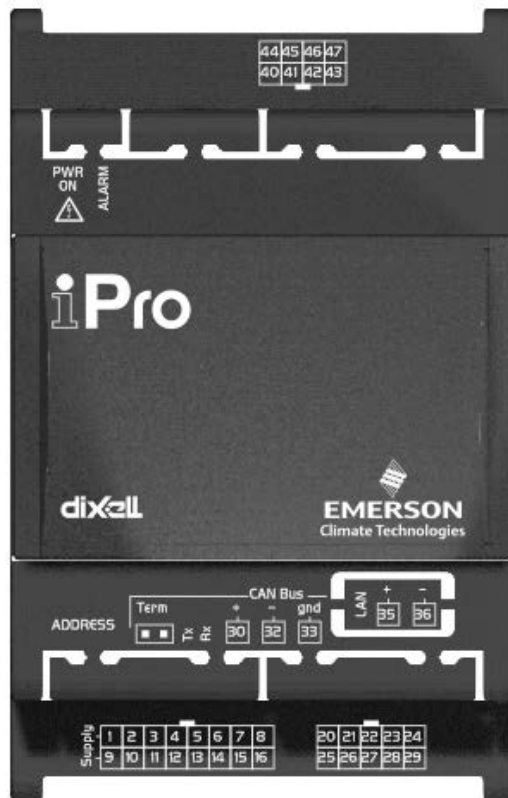

4.7.1 Description of the connections

Connector	Description
	Connector for 24Vac/dc power supply Analogue inputs (Pb1 - Pb5, PbC) Potential free digital inputs (DI1 - DI3, DIC) Additional power (+5Vdc, +12Vdc, GND)
	Analogue outputs (Out1..Out3, GND) Analogue inputs (Pb6 - Pb7, PbC) Additional power (+5Vdc, +12Vdc, GND)
	Digital relay outputs 6 NO relays, 2 common
	CANBUS Connector Rx and Tx LED to indicate that communication is active Line terminal (Term)
	LAN serial port connector
ADDRESS	Dip-switch to set the address of the device.
PWR ON	Green LED to indicate the presence of power
ALARM	Red status LED (ALARM) See relative paragraph

4.7.2 Description of the inputs and outputs

Input No.	Type of Input	Description
1	Supply	Reference “-“/GND power (24Vac or 24Vdc)
2	Pb1	Configurable analogue input 1 (NTC, PTC, PT1000, 0 - 20mA, 4 - 20mA, 0 - 5V, 0 - 1V, 0 - 10V, DI, not used)
3	Pb2	Configurable analogue input 2 (NTC, PTC, PT1000, 0 - 20mA, 4 - 20mA, 0 - 5V, 0 - 1V, 0 - 10V, DI, not used)
4	Pb3	Configurable analogue input 3 (NTC, PTC, PT1000, 0 - 20mA, 4 - 20mA, 0 - 5V, 0 - 1V, 0 - 10V, DI, not used)
5	Pb4	Configurable analogue input 4 (NTC, PTC, PT1000, 0 - 20mA, 4 - 20mA, 0 - 5V, 0 - 1V, 0 - 10V, DI, not used)
6	Pb5	Configurable analogue input 5 (NTC, PTC, PT1000, 0 - 20mA, 4 - 20mA, 0 - 5V, 0 - 1V, 0 - 10V, DI, not used)
7	+12V	Additional power +12Vdc
8	+12V	Additional power +12Vdc
9	Supply	Reference “+“ power supply (24Vac or 24Vdc)
10	DI1	Digital input 1 (potential free contact)
11	DI2	Digital input 2 (potential free contact)
12	DI3	Digital input 3 (potential free contact)
13	DIC	Common digital inputs 1 to 3
14	Pbc	Common analogue inputs (NTC, PTC, PT1000, DI)
15	GND(-)	Additional power reference 5Vdc and 12Vdc and analogue inputs (0 - 20mA, 4 - 20mA, 0 - 10V, 0 - 1V, 0 - 5V)
16	+5V	Additional power +5Vdc
20	GND(-)	Additional power reference 5Vdc, 12Vdc and analogue outputs
21	Out1	Analogue output 1 0 - 10V
22	Out2	Analogue output 2 0 - 10V
23	Out3	Analogue output 3 0 - 10V
24	Pb6	Configurable analogue input 6 (NTC, PTC, PT1000, 0 - 20mA, 4 - 20mA, 0 - 5V, 0 - 1V, 0 - 10V, DI, not used)
25	GND(-)	Additional power reference 5Vdc, 12Vdc and analogue outputs
26	+12V	Additional power +12Vdc
27	+5V	Additional power +5Vdc
28	Pbc	Common analogue inputs (NTC, PTC, PT1000, DI)
29	Pb7	Configurable analogue input 7 (NTC, PTC, PT1000, 0 - 20mA, 4 - 20mA, 0 - 5V, 0 - 1V, 0 - 10V, DI, not used)
30	CAN Bus	CAN Bus connection (+), not open
32	CAN Bus	CAN Bus connection (-), not open
33	CAN Bus	CAN Bus connection (gnd), not open
35	LAN	LAN connection (+)
36	LAN	LAN connection (-)
40	RL4	Relay 4 normally open contact
41	RL5	Relay 5 normally open contact
42	RL6	Relay 6 normally open contact
43	C	Common relays 5, 6 and 3 (MAX 6A)
44	C	Common relays 1, 2 and 4 (MAX 6A)
45	RL1	Relay 1 normally open contact
46	RL2	Relay 2 normally open contact
47	RL3	Relay 3 normally open contact

4.7.3 Technical specifications

4.7.3.1 Analogue inputs

Analogue conversion type:	10-bit A/D converter
Number of inputs:	7
Type of analogue input: (configurable via software parameter)	NTC Dixell (-50T110°C; 10KΩ±1% at 25°C) PTC Dixell(-55T115°C; 990Ω±1% at 25°C) PT1000 Dixell (-100T150°C; 1KΩ at 0°C) Digital input (potential free contact) Voltage: 0 - V, 0 - 5V, 0 - 10V (input resistance 3.7KΩ) Current: 0 - 20mA, 4 - 20mA (input resistance 100Ω)
Digital input status variation detection time:	100ms (in any case it depends on the cycle time set by the user in the given application)
Accuracy:	NTC, PTC, PT1000: ±1°C 0-1V: ±20mV 0-5V: ±100mV 0-10V:±200mV 2-20mA, 4-20mA: ±0.30mA
Additional power:	+12V: 40mA max per terminal +5v: 100mA
Notes: 	Any inputs that are powered with a voltage that differs from that supplied by the device (+12V or +5V) must be powered separately with another transformer (do not use the same secondary of the controller's power) in order to prevent the inputs from malfunctioning or being damaged.

4.7.3.2 Digital inputs

Type: (configurable via software parameter)	Opto-insulated potential free contact
Number of inputs:	3
Digital input status variation detection time:	100ms (in any case it depends on the cycle time set by the user in the given application)
Notes: 	Do not use live contacts in order to prevent the inputs from being damaged.

4.7.3.3 Analogue outputs

Type:	Non opto-insulated internal power
Number of outputs:	3
Type of analogue output: (configurable via software parameter)	3 fixed outputs 0-10Vdc (Out1 - Out3)
Maximum load:	40mA (Out1 - Out3) 22Ω per live analogue output
Accuracy:	Out1 - Out3: ±2% full scale
Resolution:	8bit
Notes: 	The electrical devices controlled by these analogue outputs must be powered separately with another transformer (do not use the same secondary of the controller's power) in order to prevent the outputs from malfunctioning or being damaged.

4.7.3.4 Digital outputs

Type:	Relays with NO contacts
Number of outputs:	6
Type of output: (configurable via software parameter)	Relays with normally open contact:
Maximum load:	5A(250Vac) SPST 5(2)A
Notes: 	Verify the capacity of the output used. There is double insulation between the digital outputs and the low voltage of the rest of the circuit. The common relays of the outputs are separate and split into groups.

4.7.3.5 Wiring diagrams

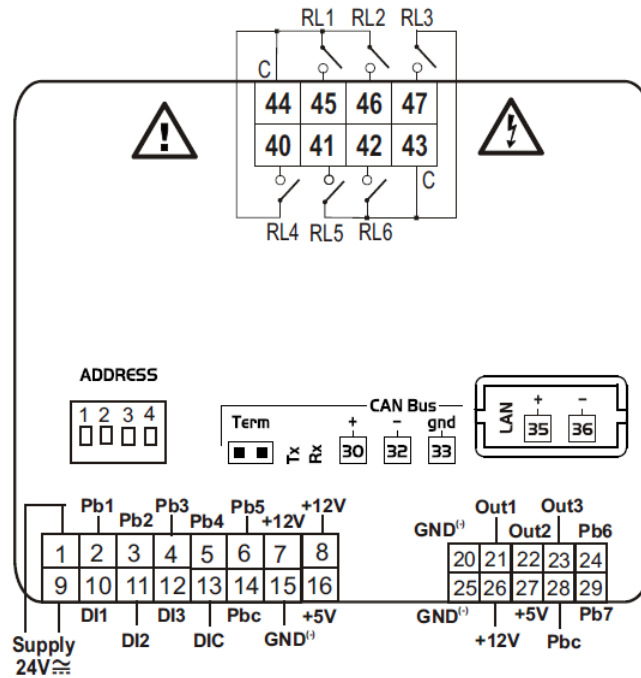

4.7.3.6 Mechanical specifications

4 DIN module

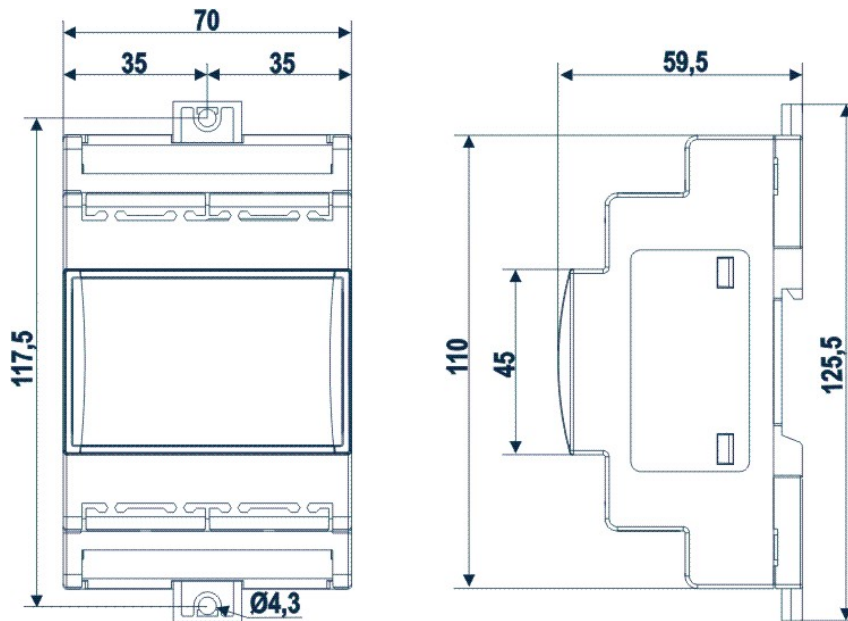

4.7.3.7 Electrical specifications

Power Supply:	24Vac +10/-15%, 50/60Hz 20 - 36Vdc
Consumption:	10VA (Vac), 10W (Vdc)
Connectors:	Molex connectors with low voltage wiring SELECOM/CIVILUX connectors for digital outputs (250Vac, 6A max) or with a different order code: Phoenix quick coupling connectors for low voltage STELVIO 90° screw connectors for digital outputs (250Vac, 6A max)

4.7.3.8 Plastic container

Mount:	On a DIN rail (EN 50022, DIN 43880) Fastened with screws via the removable plastic flaps.
Material:	PC-ABS Thermoplastic
Self-extinguishing:	V0 (UL94)
Comparative Tracking Index (CTI):	300V
Colour:	Black

4.7.3.9 Setting the address of the device

The address of the device is set via a dip-switch and numbering is binary as shown in the table below:



	1	2	3	4
Adr. 0	OFF	OFF	OFF	OFF
Adr. 1	ON	OFF	OFF	OFF
Adr. 2	OFF	ON	OFF	OFF
Adr. 3	ON	ON	OFF	OFF
Adr. 4	OFF	OFF	ON	OFF
Adr. 5	ON	OFF	ON	OFF
Adr. 6	OFF	ON	ON	OFF
Adr. 7	ON	ON	ON	OFF
Adr. 8	OFF	OFF	OFF	ON
Adr. 9	ON	OFF	OFF	ON
Adr. 10	OFF	ON	OFF	ON
Adr. 11	ON	ON	OFF	ON
Adr. 12	OFF	OFF	ON	ON
Adr. 13	ON	OFF	ON	ON
Adr. 14	OFF	ON	ON	ON
Adr. 15	ON	ON	ON	ON



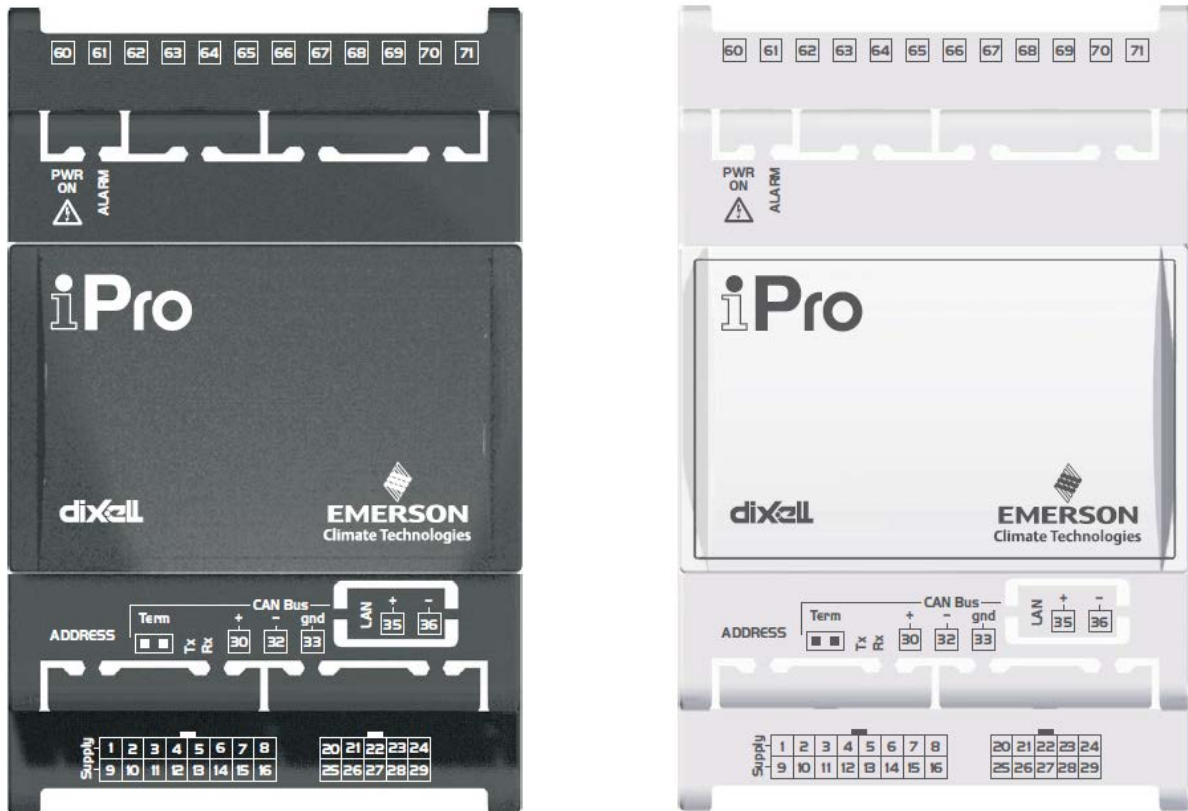

← Not used

If the address is changed while the device is switched on, to confirm the new address remember to switch off and switch on again the device.

4.8 IPX206D – IPX306D

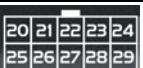

4.8.1 Description of the connections

Connector	Description
	Connector for 24Vac/dc power supply Analogue inputs (Pb1 - Pb5, PbC) Potential free digital inputs (DI1 - DI3, DIC) or Power supply digital inputs (DI1 - DI3, ID) Additional power (+5Vdc, +12Vdc, GND)
	Analogue outputs (Out1..Out3, GND) Analogue inputs (Pb6 - Pb7, PbC) Additional power (+5Vdc, +12Vdc, GND)
	Digital relay outputs (depend on the part number of the device): 5 NO relays + 1 changeover relay or 4 NO relays + 1 changeover relay + 1 SSR relay
	CANBUS Connector Rx and Tx LED to indicate that communication is active Line terminal (Term)
	LAN serial port connector
ADDRESS	Dip-switch to set the address of the device (for CANBUS and LAN communication).
PWR ON	Green LED to indicate the presence of the power supply
ALARM	Red status LED (ALARM) See relative paragraph

4.8.2 Description of the inputs and outputs

Input	Type of Input	Description
1	Supply	Reference “-“/GND power (24Vac or 24Vdc)
2	Pb1	Configurable analogue input 1 (NTC, PTC, PT1000, 0 - 20mA, 4 - 20mA, 0 - 5V, 0 - 1V, 0 - 10V, DI, not used)
3	Pb2	Configurable analogue input 2 (NTC, PTC, PT1000, 0 - 20mA, 4 - 20mA, 0 - 5V, 0 - 1V, 0 - 10V, DI, not used)
4	Pb3	Configurable analogue input 3 (NTC, PTC, PT1000, 0 - 20mA, 4 - 20mA, 0 - 5V, 0 - 1V, 0 - 10V, DI, not used)
5	Pb4	Configurable analogue input 4 (NTC, PTC, PT1000, 0 - 20mA, 4 - 20mA, 0 - 5V, 0 - 1V, 0 - 10V, DI, not used)
6	Pb5	Configurable analogue input 5 (NTC, PTC, PT1000, 0 - 20mA, 4 - 20mA, 0 - 5V, 0 - 1V, 0 - 10V, DI, not used)
7	+12V	Additional power +12Vdc
8	ID	Common for digital inputs from 1 to 3 when power supply (24Vac/dc)
9	Supply	Reference “+“ power supply (24Vac or 24Vdc)
10	DI1	Digital input 1 (potential free contact (13) or power supply (8))
11	DI2	Digital input 2 (potential free contact (13) or power supply (8))
12	DI3	Digital input 3 (potential free contact (13) or power supply (8))
13	DIC	Common for digital inputs from 1 to 3 when potential free
14	Pbc	Common analogue inputs (NTC, PTC, PT1000, DI)
15	GND(-)	Additional power reference 5Vdc and 12Vdc and analogue inputs (0 - 20mA, 4 - 20mA, 0 - 10V, 0 - 1V, 0 - 5V)
16	+5V	Additional power +5Vdc
20	GND(-)	Additional power reference 5Vdc, 12Vdc and analogue outputs
21	Out1	Analogue output 1 0 - 10V
22	Out2	Analogue output 2 0 - 10V
23	Out3	Analogue output 3 0 - 10V
24	Pb6	Configurable analogue input 6 (NTC, PTC, PT1000, 0 - 20mA, 4 - 20mA, 0 - 5V, 0 - 1V, 0 - 10V, DI, not used)
25	GND(-)	Additional power reference 5Vdc, 12Vdc and analogue outputs
26	+12V	Additional power +12Vdc
27	+5V	Additional power +5Vdc
28	Pbc	Common analogue inputs (NTC, PTC, PT1000, DI)
29	Pb7	Configurable analogue input 7 (NTC, PTC, PT1000, 0 - 20mA, 4 - 20mA, 0 - 5V, 0 - 1V, 0 - 10V, DI, not used)
30	CAN Bus	CAN Bus connection (+), not open
32	CAN Bus	CAN Bus connection (-), not open
33	CAN Bus	CAN Bus connection (gnd), not open
35	LAN	LAN connection (+)
36	LAN	LAN connection (-)
60	RL1	Relay 1 normally open contact
61	C	Common relays 1 and 2 (MAX 5A)
62	RL2	Relay 2 normally open contact
63	RL3	Relay 3 normally open contact
64	C	Common relays 3 and 4 (MAX 5A)
65	RL4	Relay 4 normally open contact
66	C	Common relay 5 (please check the electrical characteristics of the relay used)
67	RL5	Relay 5 normally open contact (please check the electrical characteristics of the relay used)
68	NU	Not used
69	RL6	Relay 6 normally closed contact
70	RL6	Relay 6 normally open contact
71	C	Common relay 6 (MAX 8A)

4.8.3 Technical specifications

4.8.3.1 Analogue inputs

Analogue conversion type:	10-bit A/D converter
Number of inputs:	7
Type of analogue input: (configurable via software parameter)	NTC Dixell (-50T110°C; 10KΩ±1% at 25°C) PTC Dixell(-55T115°C; 990Ω±1% at 25°C) PT1000 Dixell (-100T150°C; 1KΩ at 0°C) Digital input (potential free contact) Voltage: 0 - V, 0 - 5V, 0 - 10V (input resistance 3.7KΩ) Current: 0 - 20mA, 4 - 20mA (input resistance 100Ω)
Digital input status variation detection time:	100ms (in any case it depends on the cycle time set by the user in the given application)
Accuracy:	NTC, PTC, PT1000: ±1°C 0-1V: ±20mV 0-5V: ±100mV 0-10V:±200mV 2-20mA, 4-20mA: ±0.30mA
Additional power:	+12V: 40mA max per terminal +5v: 100mA
Notes: 	Any inputs that are powered with a voltage that differs from that supplied by the device (+12V or +5V) must be powered separately with another transformer (do not use the same secondary of the controller's power) in order to prevent the inputs from malfunctioning or being damaged.

4.8.3.2 Digital inputs

Type: (configurable via software parameter)	Opto-insulated potential free contact or power supply
Number of inputs:	3
Digital input status variation detection time:	100ms (in any case it depends on the cycle time set by the user in the given application)
Notes: 	Pay attention to use the right common input when the digital inputs are used as dry contacts or power supply contacts.

4.8.3.3 Analogue outputs

Type:	Non opto-insulated internal power
Number of outputs:	3
Type of analogue output: (configurable via software parameter)	3 fixed outputs 0-10Vdc (Out1 - Out3)
Maximum load:	40mA (Out1 - Out3) 22Ω per live analogue output
Accuracy:	Out1 - Out3: ±2% full scale
Resolution:	8bit
Notes: 	The electrical devices controlled by these analogue outputs must be powered separately with another transformer (do not use the same secondary of the controller's power) in order to prevent the outputs from malfunctioning or being damaged.

4.8.3.4 Digital outputs

Type:	Relays with NO, NC and SSR contacts
Number of outputs:	6
Type of output: (configurable via software parameter)	Relays with normally open contact: - RL1, RL2, RL3, RL4, RL5* Relays with changeover contact: - RL6 SSR relays with normally open contact: - RL5* (*) the kind of the relay RL5 depend on the model of the device.
Maximum load:	Relays with normally open contact: 5A(250Vac) SPST 5(2)A Relays with changeover contact: 8A(250Vac) SPDT 8(3)A SSR relays with normally open contact 1A(12 - 250Vac): - only in AC load - minimum current is 50mA (equivalent to 12W - 250Vac) - internal impedance 300KΩ (current 0.2mA at 250Vac with an open contact)

Notes:



Verify the capacity of the output used. There is double insulation between the digital outputs and the low voltage of the rest of the circuit. The common relays of the outputs are separate and split into groups.

4.8.3.5 Wiring diagrams

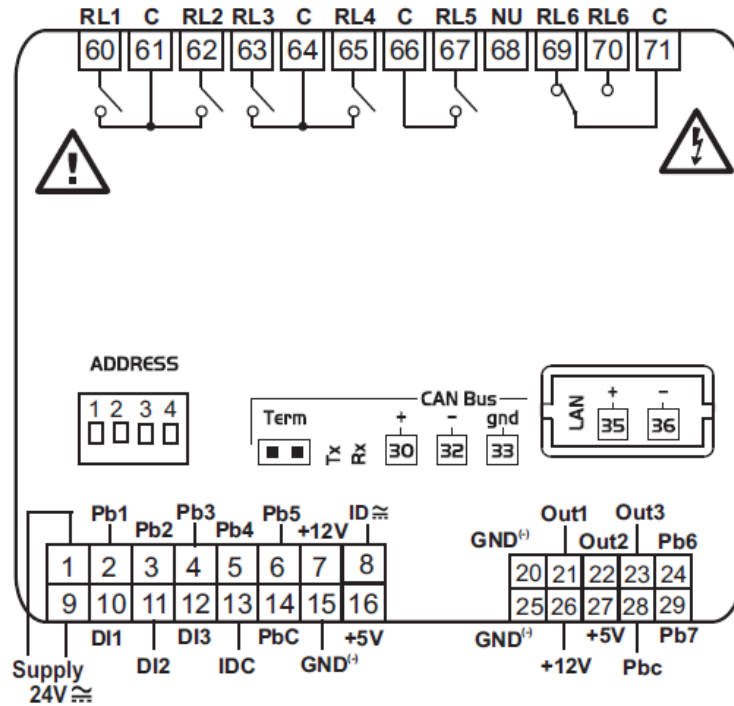

4.8.3.6 Mechanical specifications

4 DIN module

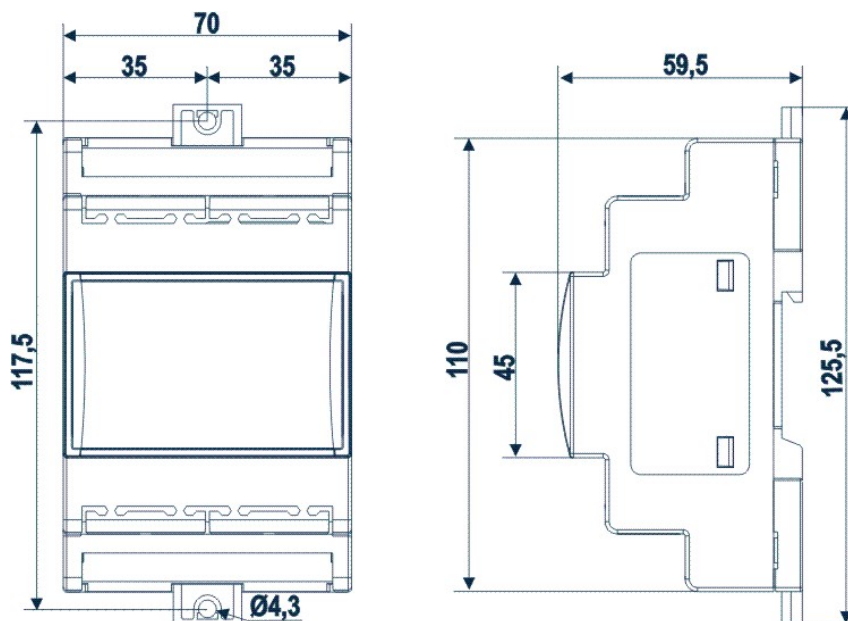

4.8.3.7 Electrical specifications

Power Supply:	24Vac +10/-15%, 50/60Hz 20 - 36Vdc
Consumption:	10VA (Vac), 10W (Vdc)
Connectors:	Molex connectors with low voltage wiring (for IPX306D) Phoenix quick coupling connectors for low voltage (for IPX206D) STELVIO 90° screw connectors for digital outputs (250Vac, 6A max)

4.8.3.8 Plastic container

Mount:	On a DIN rail (EN 50022, DIN 43880) Fastened with screws via the removable plastic flaps.
Material:	PC-ABS Thermoplastic
Self-extinguishing:	V0 (UL94)
Comparative Tracking Index (CTI):	300V
Colour:	Black

4.8.3.9 Setting the address of the device

The address of the device is set via a dip-switch and numbering is binary as shown in the table below:



	1	2	3	4
Adr. 0	OFF	OFF	OFF	OFF
Adr. 1	ON	OFF	OFF	OFF
Adr. 2	OFF	ON	OFF	OFF
Adr. 3	ON	ON	OFF	OFF
Adr. 4	OFF	OFF	ON	OFF
Adr. 5	ON	OFF	ON	OFF
Adr. 6	OFF	ON	ON	OFF
Adr. 7	ON	ON	ON	OFF
Adr. 8	OFF	OFF	OFF	ON
Adr. 9	ON	OFF	OFF	ON
Adr. 10	OFF	ON	OFF	ON
Adr. 11	ON	ON	OFF	ON
Adr. 12	OFF	OFF	ON	ON
Adr. 13	ON	OFF	ON	ON
Adr. 14	OFF	ON	ON	ON
Adr. 15	ON	ON	ON	ON

← Not used

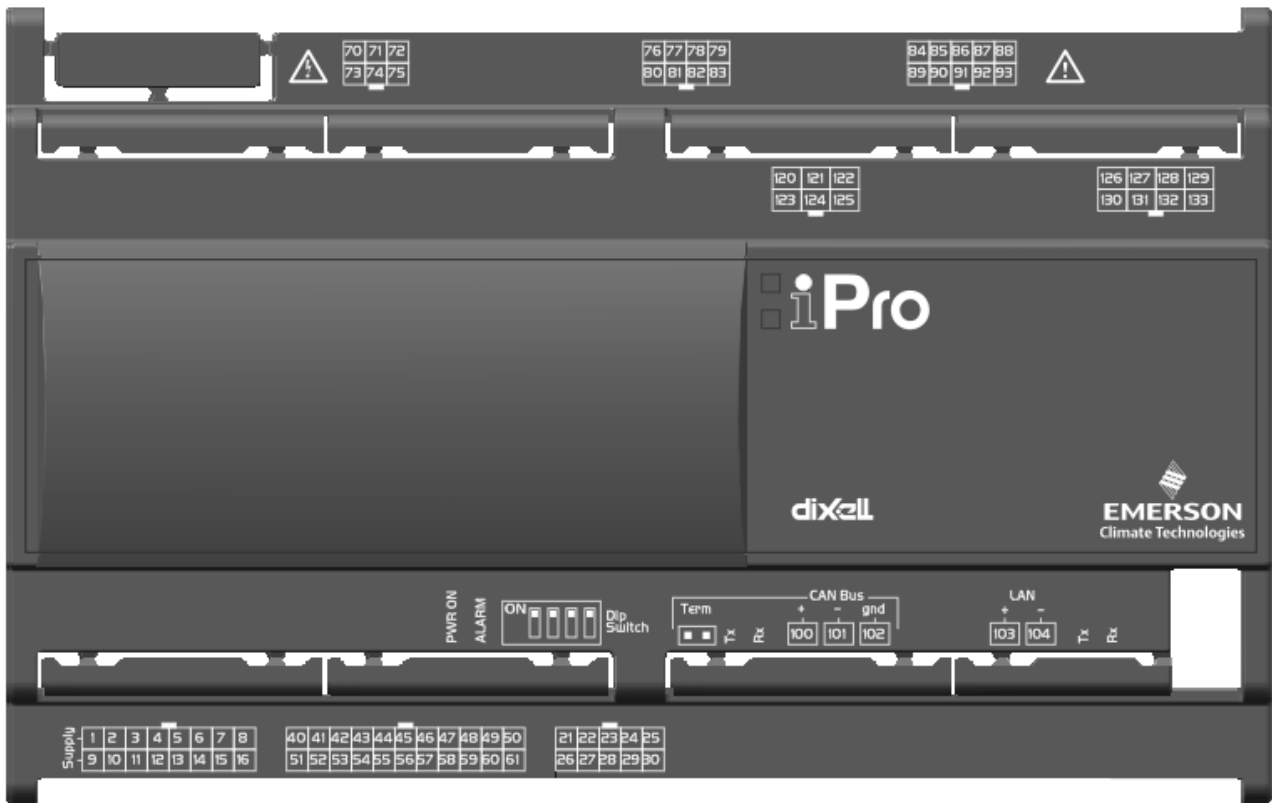

If the address is changed while the device is switched on, to confirm the new address remember to switch off and switch on again the device.

4.9 IPX115D – IPX125D



4.9.1 Description of the connections

Connector	Description
	Connector for 24Vac/dc power supply Analogue inputs (Pb1 - Pb10, PbC) Additional power (+5Vdc, +12Vdc, GND)
	Opto-insulated analogue outputs (Out1 - Out6, GND) 24Vac/dc power supply for the opto-insulated analogue output
	Potential free opto-insulated digital inputs (DI1 - DI20, DIC) Opto-insulated 24Vac/dc digital inputs (DI1 - DI20, GND)
	LAN serial port connector Rx and Tx LED to indicate that communication is active
	CANBUS Connector Rx and Tx LED to indicate that communication is active Line terminal (Term)
	Dip-switch to set the address of the device.
	Digital relay outputs 3 NO relays + 1 changeover relay, 1 common
	Digital relay outputs 6 NO relays, 2 common
	Digital relay outputs 3 NO relays + 2 changeover relays, 3 common

	Digital outputs with SSR relays (IPX125D) 4 NO relays, 2 common
	Digital relay outputs (IPX125D) 6 NO relays, 2 common
	Green power LEDs (PWR ON) and red alarm signal LED (ALARM) See relative paragraph

4.9.2 Description of the inputs and outputs

Input No.	Type of Input	Description
1	Supply	Reference “-“/GND power (24Vac or 24Vdc)
2	Pb1	Configurable analogue input 1 (NTC, PTC, PT1000, 0 - 20mA, 4 - 20mA, 0 - 10V, 0 - 1V, 0 - 5V, DI)
3	Pb2	Configurable analogue input 2 (NTC, PTC, PT1000, 0 - 20mA, 4 - 20mA, 0 - 10V, 0 - 1V, 0 - 5V, DI)
4	Pb3	Configurable analogue input 3 (NTC, PTC, PT1000, 0 - 20mA, 4 - 20mA, 0 - 10V, 0 - 1V, 0 - 5V, DI)
5	Pb4	Configurable analogue input 4 (NTC, PTC, PT1000, 0 - 20mA, 4 - 20mA, 0 - 10V, 0 - 1V, 0 - 5V, DI)
6	Pb5	Configurable analogue input 5 (NTC, PTC, PT1000, 0 - 20mA, 4 - 20mA, 0 - 10V, 0 - 1V, 0 - 5V, DI)
7	PbC	Common analogue inputs (NTC, PTC, PT1000, DI)
8	GND(-)	Additional power reference 5Vdc and 12Vdc and analogue inputs (0 - 20mA, 4 - 20mA, 0 - 10V, 0 - 1V, 0 - 5V)
9	Supply	Reference “+“ power supply (24Vac or 24Vdc)
10	Pb6	Configurable analogue input 6 (NTC, PTC, PT1000, 0 - 20mA, 4 - 20mA, 0 - 10V, 0 - 1V, 0 - 5V, DI)
11	Pb7	Configurable analogue input 7 (NTC, PTC, PT1000, 0 - 20mA, 4 - 20mA, 0 - 10V, 0 - 1V, 0 - 5V, DI)
12	Pb8	Configurable analogue input 8 (NTC, PTC, PT1000, 0 - 20mA, 4 - 20mA, 0 - 10V, 0 - 1V, 0 - 5V, DI)
13	Pb9	Configurable analogue input 9 (NTC, PTC, PT1000, 0 - 20mA, 4 - 20mA, 0 - 10V, 0 - 1V, 0 - 5V, DI)
14	Pb10	Configurable analogue input 10 (NTC, PTC, PT1000, 0 - 20mA, 4 - 20mA, 0 - 10V, 0 - 1V, 0 - 5V, DI)
15	+5V	Additional power +5Vdc
16	+12V	Additional power +12Vdc
21	Out1	Opto-insulated analogue output 1 0 - 10V
22	Out2	Opto-insulated analogue output 2 0 - 10V
23	Out3	Opto-insulated analogue output 3 0 - 10V
24	Out4	Opto-insulated analogue output 4 0 - 10V
25	GND(-)	Common opto-insulated analogue output
26	Out5	Analogue output 5 0 - 10V, 4 - 20mA, Opto-insulated relay
27	Out6	Analogue output 6 0 - 10V, 4 - 20mA, Opto-insulated relay
28	Supply	Power for opto-insulated analogue outputs at 24Vac or 24Vdc(-)
29	Supply	Power for opto-insulated analogue outputs at 24Vac or 24Vdc(+)
30	GND(-)	Common opto-insulated analogue output
40	DI1	Opto-insulated digital input 1
41	DI2	Opto-insulated digital input 2
42	DI3	Opto-insulated digital input 3
43	DI4	Opto-insulated digital input 4
44	DI5	Opto-insulated digital input 5
45	DI6	Opto-insulated digital input 6
46	DI7	Opto-insulated digital input 7
47	DI8	Opto-insulated digital input 8

48	DI9	Opto-insulated digital input 9
49	DI10	Opto-insulated digital input 10
50	GND(-)	Reference “-“ for opto-insulated digital inputs 1 to 20 (if inputs 24Vac or 24Vdc)
51	DI11	Opto-insulated digital input 11
52	DI12	Opto-insulated digital input 12
53	DI13	Opto-insulated digital input 13
54	DI14	Opto-insulated digital input 14
55	DI15	Opto-insulated digital input 15
56	DI16	Opto-insulated digital input 16
57	DI17	Opto-insulated digital input 17
58	DI18	Opto-insulated digital input 18
59	DI19	Opto-insulated digital input 19
60	DI20	Opto-insulated digital input 20
61	IDC	Common opto-insulated digital inputs 1 to 20 (if potential free inputs)
70	RL1	Relay 1 normally open contact
71	RL2	Relay 2 normally open contact
72	RL3	Relay 3 normally open contact
73	C	Common relays 1, 2, 3 and 4 (MAX 6A)
74	RL4	Relay 4 normally open contact
75	RL3	Relay 3 normally closed contact
76	C	Common relays 5, 8 and 9 (MAX 6A)
77	RL5	Relay 5 normally open contact
78	RL6	Relay 6 normally open contact
79	RL7	Relay 7 normally open contact
80	RL8	Relay 8 normally open contact
81	RL9	Relay 9 normally open contact
82	RL10	Relay 10 normally open contact
83	C	Common relays 6, 7 and 10 (MAX 6A)
84	RL11	Relay 11 normally open contact
85	RL12	Relay 12 normally open contact
86	RL13	Relay 13 normally open contact
87	C	Common relays 12, 13 and 15 (MAX 6A)
88	C	Common relays 12, 13 and 15 (MAX 6A)
89	RL11	Relay 11 normally closed contact
90	C	Common relays 11 and 14 (MAX 6A)
91	RL14	Relay 14 normally open contact
92	RL14	Relay 14 normally closed contact
93	RL15	Relay 15 normally open contact
100	CAN Bus	CAN Bus connection (+), not open
101	CAN Bus	CAN Bus connection (-), not open
102	CAN Bus	CAN Bus connection (insulated gnd), not open
103	LAN	LAN Connection (+)
104	LAN	LAN Connection (-)
120	RL16	SSR relay 16 normally open contact
121	C	Common relays 16, 17, 18 and 19
122	RL18	SSR relay 18 normally open contact
123	RL17	SSR relay 17 normally open contact
124	C	Common relays 16, 17, 18 and 19
125	RL19	SSR relay 19 normally open contact
126	RL20	Relay 20 normally open contact

127	RL21	Relay 21 normally open contact
128	C	Common relays 20, 21, 22, 23, 24 and 25 (MAX 6A)
129	RL22	Relay 22 normally open contact
130	RL23	Relay 23 normally open contact
131	RL24	Relay 24 normally open contact
132	C	Common relays 20, 21, 22, 23, 24 and 25 (MAX 6A)
133	RL25	Relay 25 normally open contact

4.9.3 Technical specifications

4.9.3.1 Analogue inputs

Analogue conversion type:	10-bit A/D converter
Number of inputs:	10
Type of analogue input: (configurable via software parameter)	NTC Dixell (-50T110°C; 10KΩ±1% at 25°C) PTC Dixell(-55T115°C; 990Ω±1% at 25°C) PT1000 Dixell (-100T150°C; 1KΩ at 0°C) Digital input (potential free contact) Voltage: 0 - V, 0 - 5V, 0 - 10V (input resistance 15KΩ) Current: 0 - 20mA, 4 - 20mA (input resistance 100Ω)
Digital input status variation detection time:	100ms (in any case it depends on the cycle time set by the user in the given application)
Accuracy:	NTC, PTC, PT1000: ±1°C 0-1V: ±20mV 0-5V: ±100mV 0-10V:±200mV 2-20mA, 4-20mA: ±0.30mA
Additional power:	+12V: 200mA max +5v: 100mA
Notes: 	Any inputs that are powered with a voltage that differs from that supplied by the device (+12V or +5V) must be powered separately with another transformer (do not use the same secondary of the controller's power) in order to prevent the inputs from malfunctioning or being damaged.

4.9.3.2 Digital inputs

Type: (configurable via software parameter)	Opto-insulated potential free or live contact (24Vac/dc) External power 24Vac/dc ±20%
Number of inputs:	20
Digital input status variation detection time:	100ms (in any case it depends on the cycle time set by the user in the given application)
Notes: 	If the digital inputs are used with voltage, use another transformer (do not use the same secondary of the controller's power) in order to prevent the inputs from malfunctioning or being damaged.

4.9.3.3 Analogue outputs

Type:	Opto-insulated with separate 24Vac/dc power supply
Number of outputs:	6
Type of analogue output: (configurable via software parameter)	4 fixed outputs 0-10Vdc (Out1 - Out4) 2 configurable outputs 0-10Vdc, 4-20mA (Out5 and Out6)
Maximum load:	40mA (Out1 - Out4) 20mA (Out5 and Out6) max with configured outputs 0-10Vdc 400Ω max with configured outputs 4-20mA 22Ω per live analogue output
Accuracy:	Out1 - Out4: ±2% full scale Out5 – Out6: ±2% full scale
Resolution:	8bit
Notes: 	The electrical devices controlled by these analogue outputs must be powered separately with another transformer (do not use the same secondary of the controller's power) in order to prevent the outputs from malfunctioning or being damaged.

4.9.3.4 Digital outputs

Type:	Relays with NO, NC and SSR contacts
Number of outputs:	25
Type of output: (configurable via software parameter)	Relays with normally open contact: - RL1, RL2, RL4, RL5, RL6, RL7, RL8, RL9, RL10, RL12, RL13, RL15, RL20, RL21, RL22, RL23, RL24, RL25 Relays with changeover contact: - RL3, RL11, RL14 SSR relays: - RL16, RL17, RL18, RL19
Maximum load:	Relays with normally open contact: 5A(250Vac) SPST 5(2)A Relays with changeover contact: 8A(250Vac) SPDT 8(3)A SSR relays with normally open contact 1A(12 - 250Vac): - only in AC load - minimum current is 50mA (equivalent to 12W - 250Vac) - internal impedance 300KΩ (current 0.2mA at 250Vac with an open contact)
Notes: 	Verify the capacity of the output used. There is double insulation between the digital outputs and the low voltage of the rest of the circuit. Do not use different voltages for the various groups of relays nor within each group.

4.9.3.5 Wiring diagrams

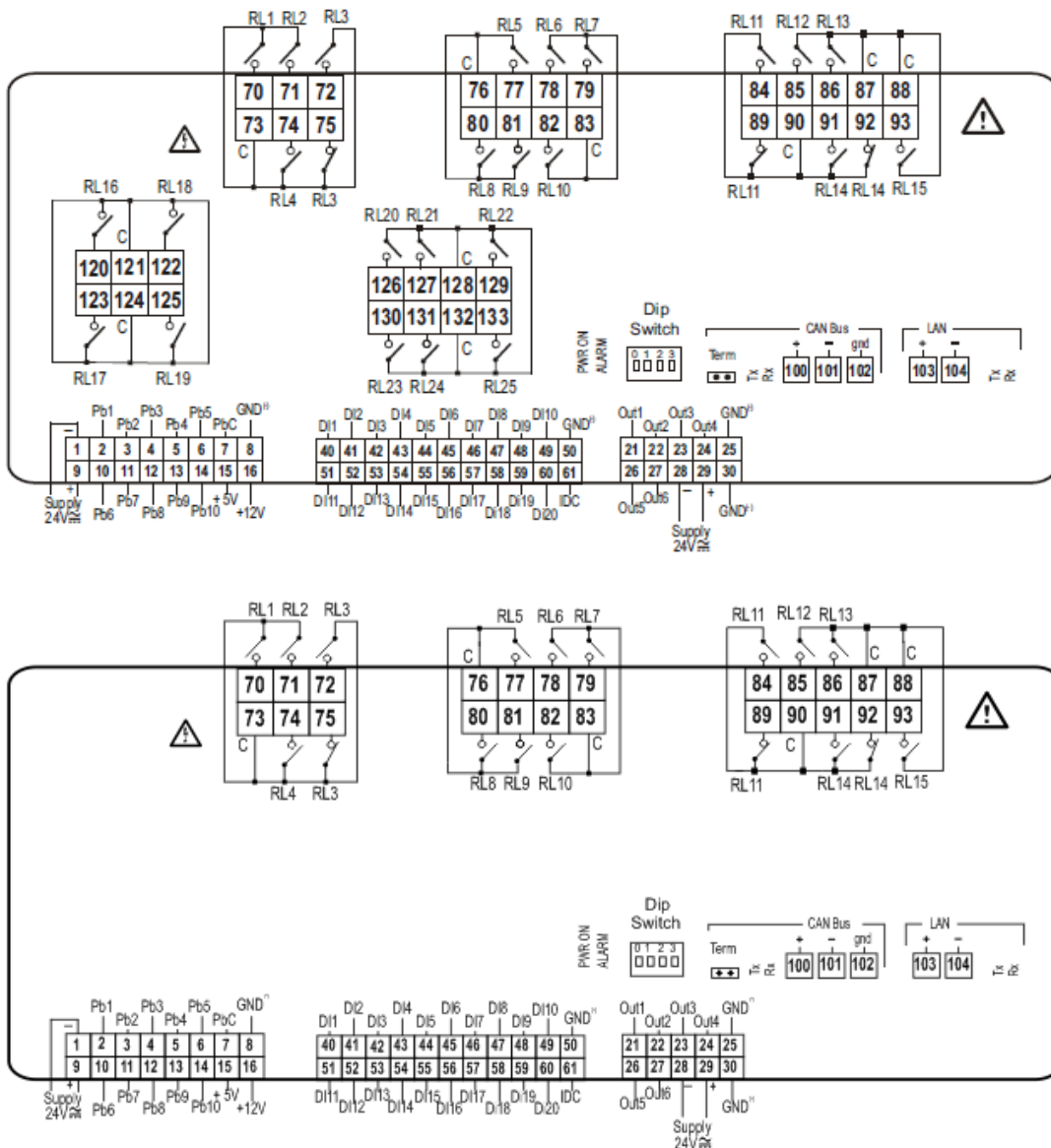

4.9.3.6 Mechanical specifications

10 DIN module

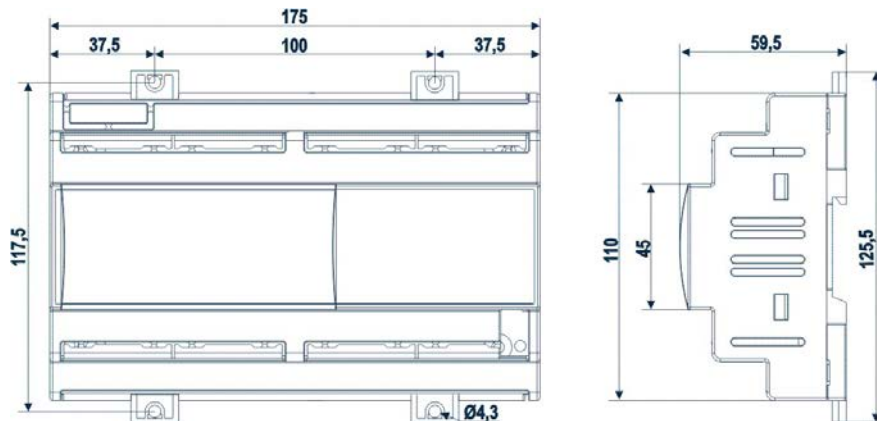

4.9.3.7 Electrical specifications

Power Supply:	24Vac +10/-15%, 50/60Hz 20 - 36Vdc
Consumption:	20VA (Vac), 15W (Vdc)
Connectors:	Molex connectors with low voltage wiring SELECOM/CIVILUX connectors for digital outputs (250Vac, 6A max)

4.9.3.8 Plastic container

Mount:	On a DIN rail (EN 50022, DIN 43880) Fastened with screws via the removable plastic flaps.
Material:	PC-ABS Thermoplastic
Self-extinguishing:	V0 (UL94)
Comparative Tracking Index (CTI):	300V
Colour:	Black

4.9.3.9 Setting the address of the device

The address of the device is set via a dip-switch and numbering is binary as shown in the table below:



	1	2	3	4
Adr. 0	OFF	OFF	OFF	OFF
Adr. 1	ON	OFF	OFF	OFF
Adr. 2	OFF	ON	OFF	OFF
Adr. 3	ON	ON	OFF	OFF
Adr. 4	OFF	OFF	ON	OFF
Adr. 5	ON	OFF	ON	OFF
Adr. 6	OFF	ON	ON	OFF
Adr. 7	ON	ON	ON	OFF
Adr. 8	OFF	OFF	OFF	ON
Adr. 9	ON	OFF	OFF	ON
Adr. 10	OFF	ON	OFF	ON
Adr. 11	ON	ON	OFF	ON
Adr. 12	OFF	OFF	ON	ON
Adr. 13	ON	OFF	ON	ON
Adr. 14	OFF	ON	ON	ON
Adr. 15	ON	ON	ON	ON

← Not used

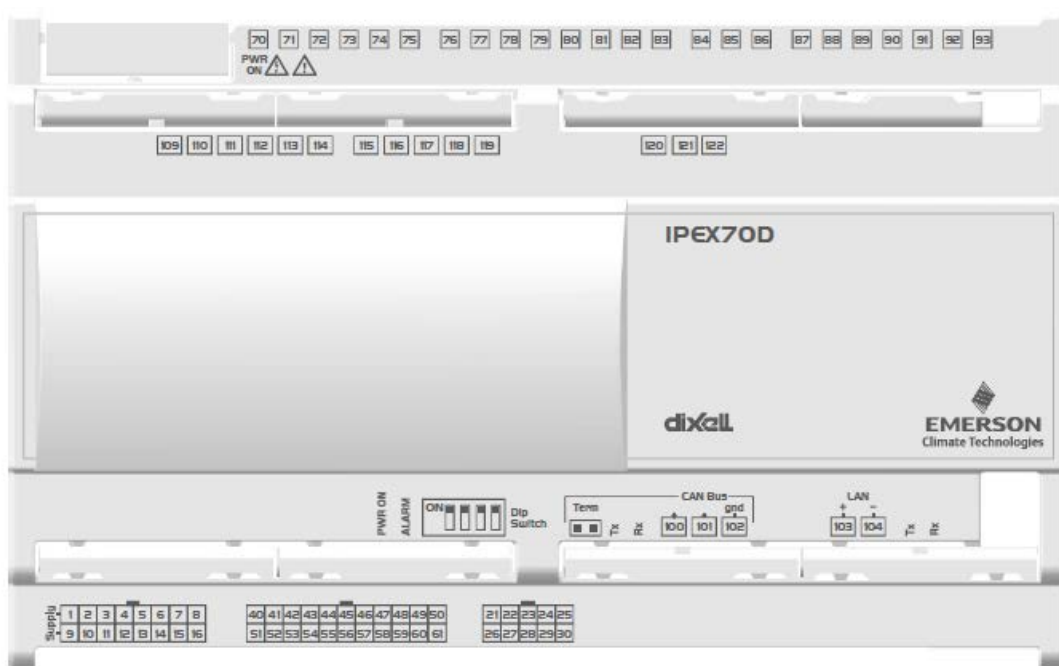

If the address is changed while the device is switched on, to confirm the new address remember to switch off and switch on again the device.

4.10 IPX215D – IPX225D



4.10.1 Description of the connections

Connector	Description
	Connector for 24Vac/dc power supply Analogue inputs (Pb1 - Pb10, PbC) Additional power (+5Vdc, +12Vdc, GND)
	Opto-insulated analogue outputs (Out1 - Out6, GND) 24Vac/dc power supply for the opto-insulated analogue output
	Potential free opto-insulated digital inputs (DI1 - DI20, DIC) Opto-insulated 24Vac/dc digital inputs (DI1 - DI20, GND)
	LAN serial port connector Rx and Tx LED to indicate that communication is active
	CANBUS Connector Rx and Tx LED to indicate that communication is active Line terminal (Term)
	Dip-switch to set the address of the device.
	Digital relay outputs 3 NO relays, 1 common and 2 potential free (Neutral)
	Digital relay outputs 5 NO relays, 1 common and 2 potential free (Neutral)
	Digital relay outputs 2 NO relays, 1 common
	Digital relay outputs 5 NO relays, 1 common and 1 potential free (Neutral) The position 93 is not connected
	Digital outputs with SSR relays 4 NO relays, 1 common The position 109 is not connected

	Digital relay outputs 4 NO relays, 1 common
	Digital relay outputs 2 NO relays, 1 common
	Green power LEDs (PWR ON) and red alarm signal LED (ALARM) See relative paragraph

4.10.2 Description of the inputs and outputs

Input No.	Type of Input	Description
1	Supply	Reference “-“/GND power (24Vac or 24Vdc)
2	Pb1	Configurable analogue input 1 (NTC, PTC, PT1000, 0 - 20mA, 4 - 20mA, 0 - 10V, 0 - 1V, 0 - 5V, DI)
3	Pb2	Configurable analogue input 2 (NTC, PTC, PT1000, 0 - 20mA, 4 - 20mA, 0 - 10V, 0 - 1V, 0 - 5V, DI)
4	Pb3	Configurable analogue input 3 (NTC, PTC, PT1000, 0 - 20mA, 4 - 20mA, 0 - 10V, 0 - 1V, 0 - 5V, DI)
5	Pb4	Configurable analogue input 4 (NTC, PTC, PT1000, 0 - 20mA, 4 - 20mA, 0 - 10V, 0 - 1V, 0 - 5V, DI)
6	Pb5	Configurable analogue input 5 (NTC, PTC, PT1000, 0 - 20mA, 4 - 20mA, 0 - 10V, 0 - 1V, 0 - 5V, DI)
7	PbC	Common analogue inputs (NTC, PTC, PT1000, DI)
8	GND(-)	Additional power reference 5Vdc and 12Vdc and analogue inputs (0 - 20mA, 4 - 20mA, 0 - 10V, 0 - 1V, 0 - 5V)
9	Supply	Reference “+“ power supply (24Vac or 24Vdc)
10	Pb6	Configurable analogue input 6 (NTC, PTC, PT1000, 0 - 20mA, 4 - 20mA, 0 - 10V, 0 - 1V, 0 - 5V, DI)
11	Pb7	Configurable analogue input 7 (NTC, PTC, PT1000, 0 - 20mA, 4 - 20mA, 0 - 10V, 0 - 1V, 0 - 5V, DI)
12	Pb8	Configurable analogue input 8 (NTC, PTC, PT1000, 0 - 20mA, 4 - 20mA, 0 - 10V, 0 - 1V, 0 - 5V, DI)
13	Pb9	Configurable analogue input 9 (NTC, PTC, PT1000, 0 - 20mA, 4 - 20mA, 0 - 10V, 0 - 1V, 0 - 5V, DI)
14	Pb10	Configurable analogue input 10 (NTC, PTC, PT1000, 0 - 20mA, 4 - 20mA, 0 - 10V, 0 - 1V, 0 - 5V, DI)
15	+5V	Additional power +5Vdc
16	+12V	Additional power +12Vdc
21	Out1	Opto-insulated analogue output 1 0 - 10V
22	Out2	Opto-insulated analogue output 2 0 - 10V
23	Out3	Opto-insulated analogue output 3 0 - 10V
24	Out4	Opto-insulated analogue output 4 0 - 10V
25	GND(-)	Common opto-insulated analogue output
26	Out5	Analogue output 5 0 - 10V, 4 - 20mA, Opto-insulated relay
27	Out6	Analogue output 6 0 - 10V, 4 - 20mA, Opto-insulated relay
28	Supply	Power for opto-insulated analogue outputs at 24Vac or 24Vdc(-)
29	Supply	Power for opto-insulated analogue outputs at 24Vac or 24Vdc(+)
30	GND(-)	Common opto-insulated analogue output
40	DI1	Opto-insulated digital input 1
41	DI2	Opto-insulated digital input 2
42	DI3	Opto-insulated digital input 3
43	DI4	Opto-insulated digital input 4
44	DI5	Opto-insulated digital input 5
45	DI6	Opto-insulated digital input 6
46	DI7	Opto-insulated digital input 7
47	DI8	Opto-insulated digital input 8
48	DI9	Opto-insulated digital input 9

49	DI10	Opto-insulated digital input 10
50	GND(-)	Reference "-" for opto-insulated digital inputs 1 to 20 (if inputs 24Vac or 24Vdc)
51	DI11	Opto-insulated digital input 11
52	DI12	Opto-insulated digital input 12
53	DI13	Opto-insulated digital input 13
54	DI14	Opto-insulated digital input 14
55	DI15	Opto-insulated digital input 15
56	DI16	Opto-insulated digital input 16
57	DI17	Opto-insulated digital input 17
58	DI18	Opto-insulated digital input 18
59	DI19	Opto-insulated digital input 19
60	DI20	Opto-insulated digital input 20
61	IDC	Common opto-insulated digital inputs 1 to 20 (if potential free inputs)
70	RL1	Relay 1 normally open contact
71	P	Common relays 1, 2 and 3 (MAX 6A)
72	RL2	Relay 2 normally open contact
73	RL3	Relay 3 normally open contact
74	N	Potential free contact (MAX 6A)
75	N	Potential free contact (MAX 6A)
76	RL4	Relay 4 normally open contact
77	RL5	Relay 5 normally closed contact
78	RL6	Relay 6 normally closed contact
79	RL7	Relay 7 normally closed contact
80	P	Common relays 4, 5, 6, 7 and 8 (MAX 6A)
81	RL8	Relay 8 normally closed contact
82	N	Potential free contact (MAX 6A)
83	N	Potential free contact (MAX 6A)
84	RL9	Relay 9 normally closed contact
85	RL10	Relay 10 normally closed contact
86	P	Common relays 9 and 10 (MAX 6A)
87	RL11	Relay 11 normally closed contact
88	RL12	Relay 12 normally closed contact
89	RL13	Relay 13 normally closed contact
90	P	Common relays 11, 12, 13, 14 and 15 (MAX 6A)
91	RL14	Relay 14 normally closed contact
92	RL15	Relay 15 normally closed contact
93	C	Potential free contact (MAX 6A)
100	CAN Bus	CAN Bus connection (+), not open
101	CAN Bus	CAN Bus connection (-), not open
102	CAN Bus	CAN Bus connection (insulated gnd), not open
103	LAN	LAN Connection (+)
104	LAN	LAN Connection (-)
109	C	Potential free contact (MAX 6A)
110	P	Common relays 20, 21, 22 and 23 (MAX 6A)
111	RL20	Relay 20 normally open contact
112	RL21	Relay 21 normally open contact
113	RL22	Relay 22 normally open contact
114	RL23	Relay 23 normally open contact
115	RL16	SSR relay 16 normally open contact
116	RL17	SSR relay 17 normally open contact

117	RL18	SSR relay 18 normally open contact
118	RL19	SSR relay 19 normally open contact
119	P	Common SSR relays 16, 17, 18 and 19
120	RL24	Relay 24 normally open contact
121	P	Common relays 24 and 25 (MAX 6A)
122	RL25	Relay 25 normally open contact

4.10.3 Technical specifications

4.10.3.1 Analogue inputs

Analogue conversion type:	10-bit A/D converter
Number of inputs:	10
Type of analogue input: (configurable via software parameter)	NTC Dixell (-50T110°C; 10KΩ±1% at 25°C) PTC Dixell(-55T115°C; 990Ω±1% at 25°C) PT1000 Dixell (-100T150°C; 1KΩ at 0°C) Digital input (potential free contact) Voltage: 0 - V, 0 - 5V, 0 - 10V (input resistance 15KΩ) Current: 0 - 20mA, 4 - 20mA (input resistance 100Ω)
Digital input status variation detection time:	100ms (in any case it depends on the cycle time set by the user in the given application)
Accuracy:	NTC, PTC, PT1000: ±1°C 0-1V: ±20mV 0-5V: ±100mV 0-10V:±200mV 2-20mA, 4-20mA: ±0.30mA
Additional power:	+12V: 200mA max +5v: 100mA
Notes: 	Any inputs that are powered with a voltage that differs from that supplied by the device (+12V or +5V) must be powered separately with another transformer (do not use the same secondary of the controller's power) in order to prevent the inputs from malfunctioning or being damaged.

4.10.3.2 Digital inputs

Type: (configurable via software parameter)	Opto-insulated potential free or live contact (24Vac/dc) External power 24Vac/dc ±20%
Number of inputs:	20
Digital input status variation detection time:	100ms (in any case it depends on the cycle time set by the user in the given application)
Notes: 	If the digital inputs are used with voltage, use another transformer (do not use the same secondary of the controller's power) in order to prevent the inputs from malfunctioning or being damaged.

4.10.3.3 Analogue outputs

Type:	Opto-insulated with separate 24Vac/dc power supply
Number of outputs:	6
Type of analogue output: (configurable via software parameter)	4 fixed outputs 0-10Vdc (Out1 - Out4) 2 configurable outputs 0-10Vdc, 4-20mA (Out5 and Out6)
Maximum load:	40mA (Out1 - Out4) 20mA (Out5 and Out6) max with configured outputs 0-10Vdc 400Ω max with configured outputs 4-20mA 22Ω per live analogue output
Accuracy:	Out1 - Out4: ±2% full scale Out5 - Out6: ±2% full scale
Resolution:	8bit
Notes: 	The electrical devices controlled by these analogue outputs must be powered separately with another transformer (do not use the same secondary of the controller's power) in order to prevent the outputs from malfunctioning or being damaged.

4.10.3.4 Digital outputs

Type:	Relays with NO, NC and SSR contacts
Number of outputs:	25
Type of output: (configurable via software parameter)	Relays with normally open contact: - RL1, RL2, RL3, RL4, RL5, RL6, RL7, RL8, RL9, RL10, RL11, RL12, RL13, RL14, RL15, RL20, RL21, RL22, RL23, RL24, RL25 SSR relays: - RL16, RL17, RL18, RL19
Maximum load:	Relays with normally open contact: 5A(250Vac) SPST 5(2)A SSR relays with normally open contact 1A(12 - 250Vac): - only in AC load - minimum current is 50mA (equivalent to 12W - 250Vac) - internal impedance 300KΩ (current 0.2mA at 250Vac with an open contact)
Notes: 	Verify the capacity of the output used. There is double insulation between the digital outputs and the low voltage of the rest of the circuit. Do not use different voltages for the various groups of relays nor within each group.

4.10.3.5 Wiring diagrams

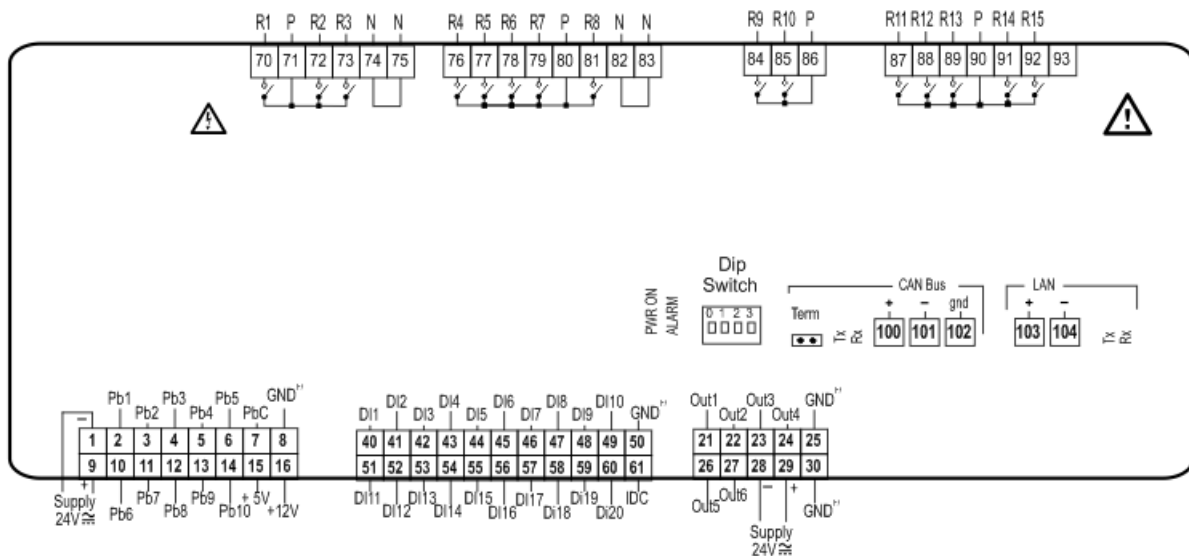
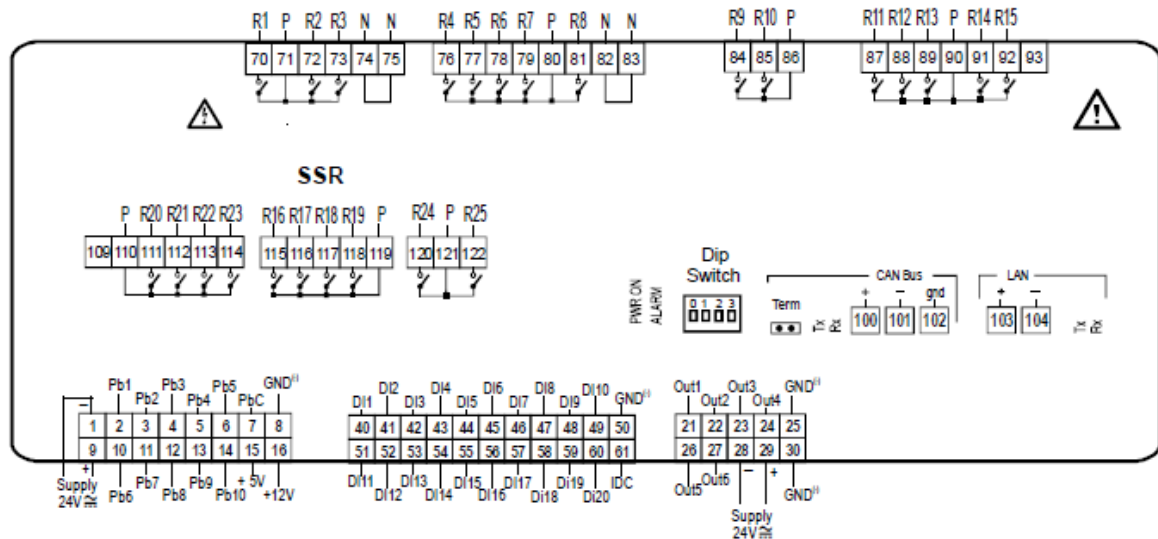

4.10.3.6 Mechanical specifications

10 DIN module

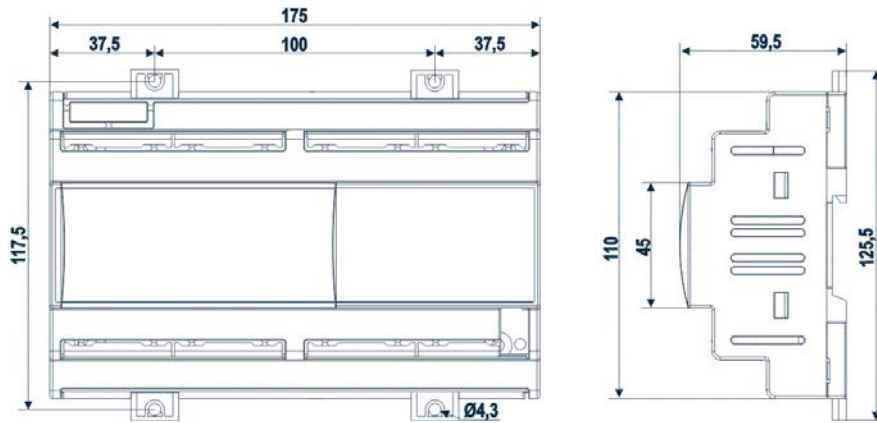

4.10.3.7 Electrical specifications

Power Supply:	24Vac +10/-15%, 50/60Hz 20 - 36Vdc
Consumption:	20VA (Vac), 15W (Vdc)
Connectors:	Phoenix quick coupling connectors for low voltage STELVIO 90° screw connectors for digital outputs (250Vac, 6A max)

4.10.3.8 Plastic container

Mount:	On a DIN rail (EN 50022, DIN 43880) Fastened with screws via the removable plastic flaps.
Material:	PC-ABS Thermoplastic
Self-extinguishing:	V0 (UL94)
Comparative Tracking Index (CTI):	300V
Colour:	White

4.10.3.9 Setting the address of the device

The address of the device is set via a dip-switch and numbering is binary as shown in the table below:



	1	2	3	4
Adr. 0	OFF	OFF	OFF	OFF
Adr. 1	ON	OFF	OFF	OFF
Adr. 2	OFF	ON	OFF	OFF
Adr. 3	ON	ON	OFF	OFF
Adr. 4	OFF	OFF	ON	OFF
Adr. 5	ON	OFF	ON	OFF
Adr. 6	OFF	ON	ON	OFF
Adr. 7	ON	ON	ON	OFF
Adr. 8	OFF	OFF	OFF	ON
Adr. 9	ON	OFF	OFF	ON
Adr. 10	OFF	ON	OFF	ON
Adr. 11	ON	ON	OFF	ON
Adr. 12	OFF	OFF	ON	ON
Adr. 13	ON	OFF	ON	ON
Adr. 14	OFF	ON	ON	ON
Adr. 15	ON	ON	ON	ON







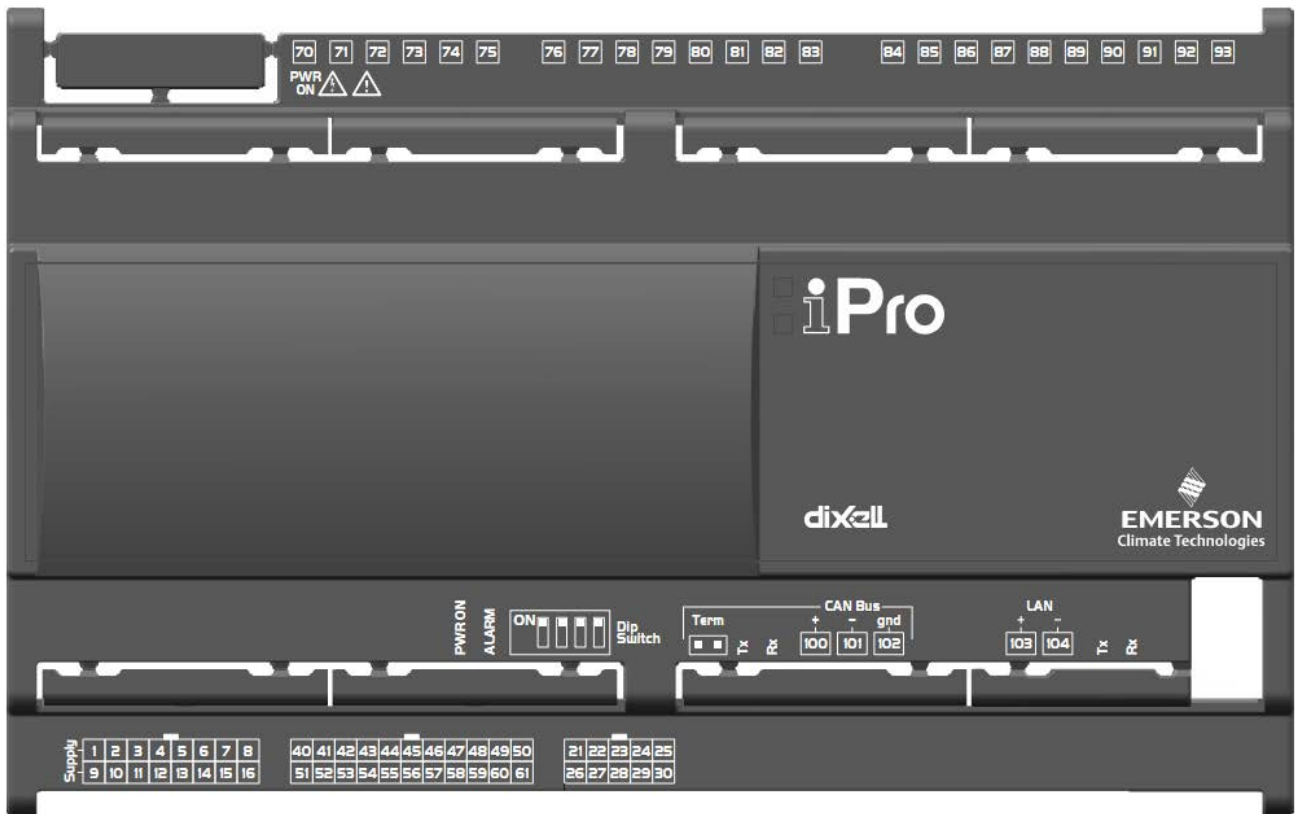

← Not used

If the address is changed while the device is switched on, to confirm the new address remember to switch off and switch on again the device.

4.11 IPX315D

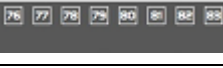

4.11.1 Description of the connections

Connector	Description
	Connector for 24Vac/dc power supply Analogue inputs (Pb1 - Pb10, PbC) Additional power (+5Vdc, +12Vdc, GND)
	Opto-insulated analogue outputs (Out1 - Out6, GND) 24Vac/dc power supply for the opto-insulated analogue output
	Potential free opto-insulated digital inputs (DI1 - DI20, DIC) Opto-insulated 24Vac/dc digital inputs (DI1 - DI20, GND)
	LAN serial port connector Rx and Tx LED to indicate that communication is active
	CANBUS Connector Rx and Tx LED to indicate that communication is active Line terminal (Term)
	Dip-switch to set the address of the device.
	Digital relay outputs 4 NO relays, 2 common
	Digital relay outputs 3 NO relays, 1 common + 3 NO relays, 1 common
	Digital relay outputs 3 NO relays, 2 common + 2 NO relays, 3 common

4.11.2 Description of the inputs and outputs

Input No.	Type of Input	Description
1	Supply	Reference “-“/GND power (24Vac or 24Vdc)
2	Pb1	Configurable analogue input 1 (NTC, PTC, PT1000, 0 - 20mA, 4 - 20mA, 0 - 10V, 0 - 1V, 0 - 5V, DI)
3	Pb2	Configurable analogue input 2 (NTC, PTC, PT1000, 0 - 20mA, 4 - 20mA, 0 - 10V, 0 - 1V, 0 - 5V, DI)
4	Pb3	Configurable analogue input 3 (NTC, PTC, PT1000, 0 - 20mA, 4 - 20mA, 0 - 10V, 0 - 1V, 0 - 5V, DI)
5	Pb4	Configurable analogue input 4 (NTC, PTC, PT1000, 0 - 20mA, 4 - 20mA, 0 - 10V, 0 - 1V, 0 - 5V, DI)
6	Pb5	Configurable analogue input 5 (NTC, PTC, PT1000, 0 - 20mA, 4 - 20mA, 0 - 10V, 0 - 1V, 0 - 5V, DI)
7	PbC	Common analogue inputs (NTC, PTC, PT1000, DI)
8	GND(-)	Additional power reference 5Vdc and 12Vdc and analogue inputs (0 - 20mA, 4 - 20mA, 0 - 10V, 0 - 1V, 0 - 5V)
9	Supply	Reference “+“ power supply (24Vac or 24Vdc)
10	Pb6	Configurable analogue input 6 (NTC, PTC, PT1000, 0 - 20mA, 4 - 20mA, 0 - 10V, 0 - 1V, 0 - 5V, DI)
11	Pb7	Configurable analogue input 7 (NTC, PTC, PT1000, 0 - 20mA, 4 - 20mA, 0 - 10V, 0 - 1V, 0 - 5V, DI)
12	Pb8	Configurable analogue input 8 (NTC, PTC, PT1000, 0 - 20mA, 4 - 20mA, 0 - 10V, 0 - 1V, 0 - 5V, DI)
13	Pb9	Configurable analogue input 9 (NTC, PTC, PT1000, 0 - 20mA, 4 - 20mA, 0 - 10V, 0 - 1V, 0 - 5V, DI)
14	Pb10	Configurable analogue input 10 (NTC, PTC, PT1000, 0 - 20mA, 4 - 20mA, 0 - 10V, 0 - 1V, 0 - 5V, DI)
15	+5V	Additional power +5Vdc
16	+12V	Additional power +12Vdc
21	Out1	Opto-insulated analogue output 1 0 - 10V
22	Out2	Opto-insulated analogue output 2 0 - 10V
23	Out3	Opto-insulated analogue output 3 0 - 10V
24	Out4	Opto-insulated analogue output 4 0 - 10V
25	GND(-)	Common opto-insulated analogue output
26	Out5	Analogue output 5 0 - 10V, 4 - 20mA, Opto-insulated relay
27	Out6	Analogue output 6 0 - 10V, 4 - 20mA, Opto-insulated relay
28	Supply	Power for opto-insulated analogue outputs at 24Vac or 24Vdc(-)
29	Supply	Power for opto-insulated analogue outputs at 24Vac or 24Vdc(+)
30	GND(-)	Common opto-insulated analogue output
40	DI1	Opto-insulated digital input 1
41	DI2	Opto-insulated digital input 2
42	DI3	Opto-insulated digital input 3
43	DI4	Opto-insulated digital input 4
44	DI5	Opto-insulated digital input 5
45	DI6	Opto-insulated digital input 6
46	DI7	Opto-insulated digital input 7
47	DI8	Opto-insulated digital input 8
48	DI9	Opto-insulated digital input 9
49	DI10	Opto-insulated digital input 10
50	GND(-)	Reference “-“ for opto-insulated digital inputs 1 to 20 (if inputs 24Vac or 24Vdc)
51	DI11	Opto-insulated digital input 11
52	DI12	Opto-insulated digital input 12
53	DI13	Opto-insulated digital input 13
54	DI14	Opto-insulated digital input 14
55	DI15	Opto-insulated digital input 15
56	DI16	Opto-insulated digital input 16

57	DI17	Opto-insulated digital input 17
58	DI18	Opto-insulated digital input 18
59	DI19	Opto-insulated digital input 19
60	DI20	Opto-insulated digital input 20
61	IDC	Common opto-insulated digital inputs 1 to 20 (if potential free inputs)
70	RL1	Relay 1 normally open contact
71	RL2	Relay 2 normally open contact
72	RL3	Relay 3 normally open contact
73	C	Common relays 1, 2, 3 and 4
74	RL4	Relay 4 normally open contact
75	C	Common relays 1, 2, 3 and 4
76	C	Common relays 5, 8 and 9
77	RL5	Relay 5 normally open contact
78	RL6	Relay 6 normally open contact
79	RL7	Relay 7 normally open contact
80	RL8	Relay 8 normally open contact
81	RL9	Relay 9 normally open contact
82	RL10	Relay 10 normally open contact
83	C	Common relays 6, 7 and 10
84	RL11	Relay 11 normally open contact
85	RL12	Relay 12 normally open contact
86	RL13	Relay 13 normally open contact
87	C	Common relays 12, 13 and 15
88	C	Common relays 12, 13 and 15
89	C	Common relays 11 and 14
90	C	Common relays 11 and 14
91	RL14	Relay 14 normally open contact
92	C	Common relays 11 and 14
93	RL15	Relay 15 normally open contact
100	CAN Bus	CAN Bus connection (+), not open
101	CAN Bus	CAN Bus connection (-), not open
102	CAN Bus	CAN Bus connection (insulated gnd), not open
103	LAN	LAN Connection (+)
104	LAN	LAN Connection (-)

4.11.3 Technical specifications

4.11.3.1 Analogue inputs

Analogue conversion type:	10-bit A/D converter
Number of inputs:	10
Type of analogue input: (configurable via software parameter)	NTC Dixell (-50T110°C; 10KΩ±1% at 25°C) PTC Dixell(-55T115°C; 990Ω±1% at 25°C) PT1000 Dixell (-100T150°C; 1KΩ at 0°C) Digital input (potential free contact) Voltage: 0 - V, 0 - 5V, 0 - 10V (input resistance 15KΩ) Current: 0 - 20mA, 4 - 20mA (input resistance 100Ω)
Digital input status variation detection time:	100ms (in any case it depends on the cycle time set by the user in the given application)
Accuracy:	NTC, PTC, PT1000: ±1°C 0-1V: ±20mV 0-5V: ±100mV 0-10V:±200mV 2-20mA, 4-20mA: ±0.30mA
Additional power:	+12V: 200mA max +5v: 100mA
Notes: 	Any inputs that are powered with a voltage that differs from that supplied by the device (+12V or +5V) must be powered separately with another transformer (do not use the same secondary of the controller's power) in order to prevent the inputs from malfunctioning or being damaged.

4.11.3.2 Digital inputs

Type: (configurable via software parameter)	Opto-insulated potential free or live contact (24Vac/dc) External power 24Vac/dc ±20%
Number of inputs:	20
Digital input status variation detection time:	100ms (in any case it depends on the cycle time set by the user in the given application)
Notes: 	If the digital inputs are used with voltage, use another transformer (do not use the same secondary of the controller's power) in order to prevent the inputs from malfunctioning or being damaged.

4.11.3.3 Analogue outputs

Type:	Opto-insulated with separate 24Vac/dc power supply
Number of outputs:	6
Type of analogue output: (configurable via software parameter)	4 fixed outputs 0-10Vdc (Out1 - Out4) 2 configurable outputs 0-10Vdc, 4-20mA (Out5 and Out6)
Maximum load:	40mA (Out1 - Out4) 20mA (Out5 and Out6) max with configured outputs 0-10Vdc 400Ω max with configured outputs 4-20mA 22Ω per live analogue output
Accuracy:	Out1 - Out4: ±2% full scale Out5 – Out6: ±2% full scale
Resolution:	8bit
Notes: 	The electrical devices controlled by these analogue outputs must be powered separately with another transformer (do not use the same secondary of the controller's power) in order to prevent the outputs from malfunctioning or being damaged.

4.11.3.4 Digital outputs

Type:	Relays with NO, NC and SSR contacts
Number of outputs:	25
Type of output: (configurable via software parameter)	Relays with normally open contact: - RL1, RL2, RL4, RL5, RL6, RL7, RL8, RL9, RL10, RL12, RL13, RL15, RL20, RL21, RL22, RL23, RL24, RL25 Relays with changeover contact: - RL3, RL11, RL14 SSR relays: - RL16, RL17, RL18, RL19
Maximum load:	Relays with normally open contact: 5A(250Vac) SPST 5(2)A Relays with changeover contact: 8A(250Vac) SPDT 8(3)A SSR relays with normally open contact 1A(12 - 250Vac): - only in AC load - minimum current is 50mA (equivalent to 12W - 250Vac) - internal impedance 300K Ω (current 0.2mA at 250Vac with an open contact)
Notes: 	Verify the capacity of the output used. There is double insulation between the digital outputs and the low voltage of the rest of the circuit. Do not use different voltages for the various groups of relays nor within each group.

4.11.3.5 Wiring diagrams

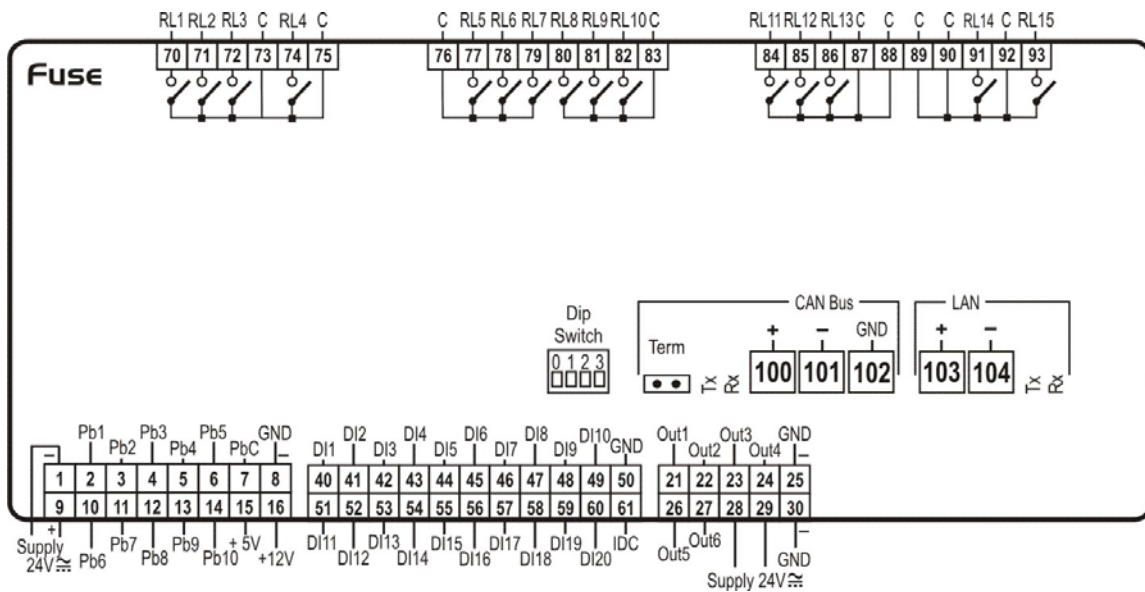

4.11.3.6 Mechanical specifications

10 DIN module

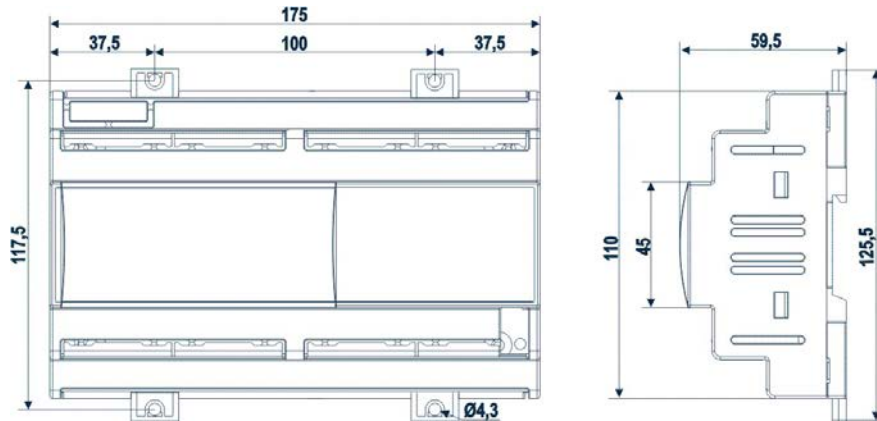

4.11.3.7 Electrical specifications

Power Supply:	24Vac +10/-15%, 50/60Hz 20 - 36Vdc
Consumption:	20VA (Vac), 15W (Vdc)
Connectors:	Molex connectors with low voltage wiring SELECOM/CIVILUX connectors for digital outputs (250Vac, 6A max)

4.11.3.8 Plastic container

Mount:	On a DIN rail (EN 50022, DIN 43880) Fastened with screws via the removable plastic flaps.
Material:	PC-ABS Thermoplastic
Self-extinguishing:	V0 (UL94)
Comparative Tracking Index (CTI):	300V
Colour:	Black

4.11.3.9 Setting the address of the device

The address of the device is set via a dip-switch and numbering is binary as shown in the table below:

		1	2	3	4	
Adr. 0		OFF	OFF	OFF	OFF	
Adr. 1		ON	OFF	OFF	OFF	
Adr. 2		OFF	ON	OFF	OFF	
Adr. 3		ON	ON	OFF	OFF	
Adr. 4		OFF	OFF	ON	OFF	
Adr. 5		ON	OFF	ON	OFF	
Adr. 6		OFF	ON	ON	OFF	
Adr. 7		ON	ON	ON	OFF	
Adr. 8		OFF	OFF	OFF	ON	
Adr. 9		ON	OFF	OFF	ON	
Adr. 10		OFF	ON	OFF	ON	
Adr. 11		ON	ON	OFF	ON	
Adr. 12		OFF	OFF	ON	ON	
Adr. 13		ON	OFF	ON	ON	
Adr. 14		OFF	ON	ON	ON	
Adr. 15		ON	ON	ON	ON	

If the address is changed while the device is switched on, to confirm the new address remember to switch off and switch on again the device.

5. INTERFACE

5.1 VISOGRAPH

The iPRO programmable controllers (10 DIN and 4 DIN) allow a programmable remote LCD display (VISOGRAPH) to be connected. Through the VISOPROG processing environment, the display and buttons can be programmed as the user wishes. Text, icons and animated icons can be added to the LCD display. Functions can be associated to keys according to the operations to be implemented.

The displays differ according to the model:

- VGIPG for IPG100 versions
- VGIPC for IPC100 versions

5.1.1 Specifications

- LCD graphic display (FSTN)
- Graphic resolution 240x96 Dots
- 32-bit microprocessor
- White backlight
- ASCII or UNICODE characters used (depending on the model)
- 8 fully programmable keys
- Programmable display and keys via VISOPROG software
- Application resident in the microprocessor of the keyboard
- Up to 5 different languages for each application
- Panel or wall mounted (depending on the model)
- Dedicated power supply and communication via a 3-way cable from the programmable controller



5.1.2 Connections

The connection between the controller and the VISOGRAPH must be implemented using a BELDEN 8772 cable (3xAWG20).

Up to 2 remote displays can be connected for each controller of the IPG, IPC and IPD ranges. 1 remote display can be connected for the controllers of the 4 DIN range.

The distance between the controller and the last display must be no more than 100 meters.

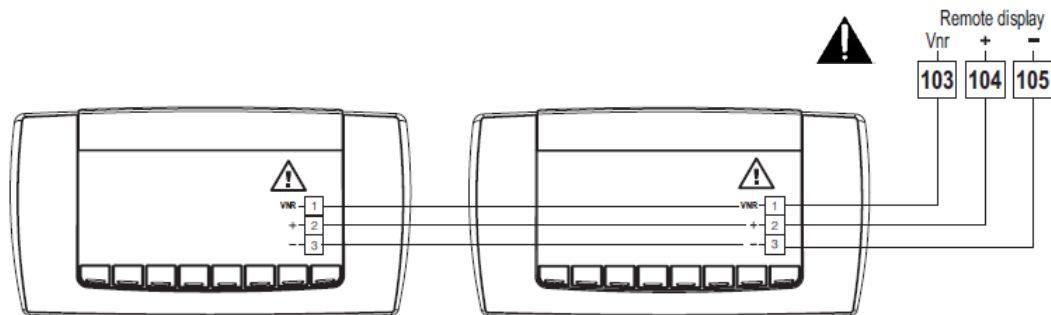

Be careful to comply with the polarity of the connections as any errors in the connection can damage the device.

5.1.3 Options menu

To enter the set up menu, keep the two extreme keys (T1 + T8) of the keyboard pressed until the window requesting the password appears.

- Press the UP key and set 1.
- Press the SET key to confirm.

The first 4 options (from 1 to 4) allow the user to UPLOAD/DOWNLOAD the Application and the Bios to the Dixell VISOKEY.

Before implementing these operations, it is recommended to contact Dixell so as to prevent the device from being damaged.

Option 5, PROGRAM INFO, displays the information of the application resident in the Visograph.

Option 6, SETTINGS, allows the user to set certain configurations:

- ADR VISOGRAPH: if two Visograph's are used with one iPRO, set two different addresses.
- CONTRAST: to adjust the contrast of the display.
- BACKLIGHT: the display backlight time is set (form 1 to 200 seconds, or always on)
- READ EXT: this must always be set to NEVER
- LANGUAGE: if different languages have been defined in the project, any one can be selected via this option.
- BAUD RATE: this must always be set to 38400
- EXIT: to exit the menu

To exit the menu permanently, press the EXIT key.

Inside the set up menu, to force the download of the application inside the Visograph please follow the the procedure:

- Keep pushed the buttons T1 and T6
- In the display you will see the sentence: "DOWNLOAD THE APPLICATION"
- Now download the application from Visoprog

Note: This procedure it is possible only if the version of the BIOS of the Visograph is the version 1.6 (23/02/2011), 8.1 (04/03/2011) or superior.



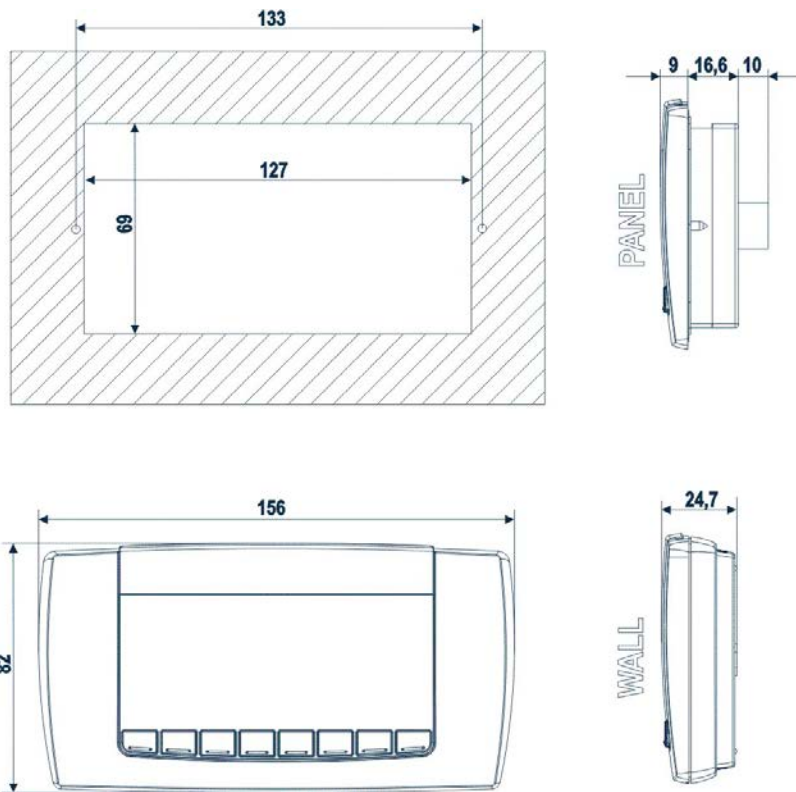

5.1.4 Dimensions



6. MEANING OF THE LEDS AND JUMPERS IN THE VARIOUS DEVICES



6.1 PROGRAMMABLE CONTROLLERS

LEDs are present in the programmable controllers in order to indicate the status of the device.

	PWR ON	<p>PWR ON (green):</p> <ul style="list-style-type: none"> - if on, the device is powered
	LED1 ALARM	<p>LED1 (yellow):</p> <ul style="list-style-type: none"> - if on, the system is being updated. - if it flashes, the update has been completed. <p>ALARM (red):</p> <ul style="list-style-type: none"> - if on, the system is malfunctioning. <p>LED1 (yellow) + ALARM (red):</p> <ul style="list-style-type: none"> - if both flash, the device is functioning correctly.
	TX RX	<p>TX (yellow):</p> <ul style="list-style-type: none"> - if it flashes, the device is transferring data. <p>RX (yellow):</p> <ul style="list-style-type: none"> - if it flashes, the device is receiving data.
	JMP1	<p>JMP1:</p> <ul style="list-style-type: none"> - if the JMP1 jumper is short-circuited, the system creates a virtual IP in order to have access to the internal website. The default IP address is 192.168.0.250 (the IP address set in the iPRO always remains the same). <p>Remove the Jumper, switch the iPRO off and on again to restore the system back to the previous conditions.</p> <p>CAUTION: this mode can only be used if the FIRMWARE version of the iPRO is 2010011300 (or higher).</p>

6.2 EXPANSION MODULES

LEDs are present in the expansion modules in order to indicate the status of the device.

	PWR ON ALARM	<p>PWR ON:</p> <ul style="list-style-type: none"> - If on, the device is powered <p>ALARM:</p> <ul style="list-style-type: none"> - if on, the system is malfunctioning. Therefore, verify the CANBus or LAN connection or the configuration/connection of the analogue inputs.
	TX RX	<p>TX:</p> <ul style="list-style-type: none"> - if it flashes, the device is transferring data. <p>RX:</p> <ul style="list-style-type: none"> - if it flashes, the device is receiving data.

7. INSTALLATION

The devices must not be installed in environments where the following situations are present:

- Temperature and humidity outside the range stipulated in the data plate. Frequent and sudden changes in temperature and/or humidity
- Direct sunlight and weathering in general
- High mechanical stress (vibrations and/or knocks)
- Sulphur and ammonia gas, smoke and salt spray that can cause corrosion and/or oxidation
- Presence of flammable or explosive gas
- Dust
- Devices that generate magnetic interference

Position the device inside the electrical panels, paying attention to the following:

- the distance between the device and the electrical power components
- the distance between the device and the power cables
- sufficient passage for the cooling air

Always comply with the laws and regulations applicable in the country where the device is installed.

Always protect the device for it to always be accessible solely by authorised personnel.

In case of malfunctions, always contact the relative distributor for the device to be repaired.

7.1 GENERAL RULES

Comply with the following recommendations during the installation process in order to prevent the device from malfunctioning.

- Separate the signal cables from the power cables (it is recommended to use BELDEN 8772-type shielded cables)
- Separate the cables of the analogue inputs from those of the digital inputs and the serial line cables from the power cables (resistive as well as inductive), in order to prevent malfunction due to electromagnetic interference
- Separate the power of the device from that of the other electrical components
- Never connect the secondary of the supply transformer to the earth
- The low voltage connections must have reinforced insulation

7.2 POWER SUPPLY

The power supply voltage of the devices is as follows:

- 24Vac +10/-15%, 50/60Hz (consumption 20VA) or 20 - 36Vdc (consumption 15W) for the programmable controllers 10 and expansion 10 DIN
- 24Vac +10/-15%, 50/60Hz (consumption 30VA) or 20 - 36Vdc (consumption 25W) for the 4 DIN programmable controllers
- 24Vac +10/-15%, 50/60Hz (consumption 10VA) or 20 - 36Vdc (consumption 10W) for the 4 DIN expansion.

Be careful to always comply with the following recommendations:

- Never use power that differs from that indicated as the devices may be damaged.
- Always use safety transformers
- Always separate the power of the controller from that of all the other electrical devices present in the system.
- The secondary of the supply transformer of the devices must never be connected to the earth.

7.3 CONNECTION OF THE ANALOGUE INPUTS

The analogue inputs in the programmable controllers and expansions are fully configurable. NTC or PTC, 0 - 20mA, 4 - 20mA, 0 - 10V, 0 - 1V or 0 - 5V type of sensors can be used.

The analogue inputs can also be used as digital inputs (potential free - not live).

NOTE: Any devices that require 24Vac/dc power supply must be powered separately with another transformer.



7.3.1 Temperature probes (NTC and PTC)

2-row sensors that do not require polarity to be respected.

Each sensor must be connected through one of the inputs (from Pb1 to Pb10) and the common (PbC) as shown in the diagram below.

IPG-IPC

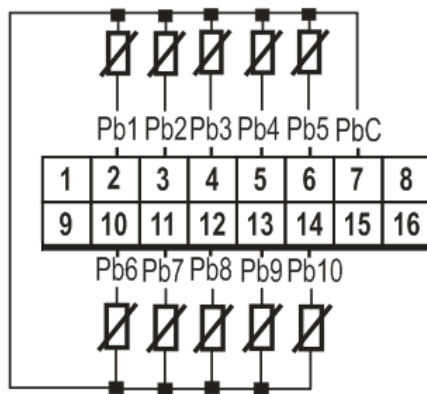

IPG-IPC 4 DIN

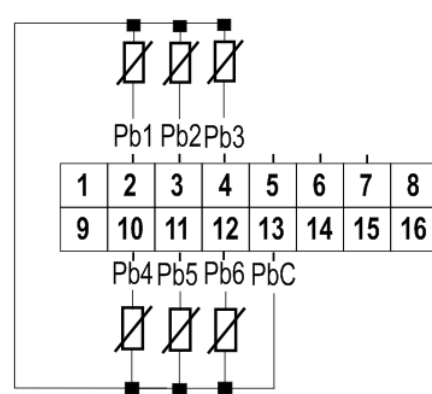

Recommendations:

- follow the diagram of the device used, for the numbering.
- the configuration is determined by the application.
- if used as a digital input (potential free - not live), use the same connection configuration of the sensors.

7.3.2 Temperature probes IPG800 Series (NTC, PTC and PT1000)

2 wires sensors that do not require polarity to be respected.

Each sensor must be connected through one of the inputs (from Pb1 to Pb7) and the common (Com) as shown in the diagram below.

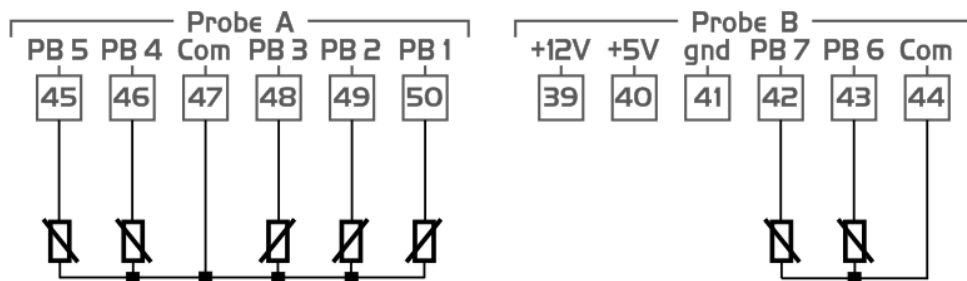

Recommendations:

- follow the diagram of the device used, for the numbering.
- the configuration is determined by the application.
- if used as a digital input (potential free - not live), use the same connection configuration of the sensors.

7.3.3 Pressure transducers and current probes (0 - 20mA, 4 - 20mA)

2-row sensors that require +12Vdc power supply.

Each sensor must be connected through one of the inputs (from Pb1 to Pb10) and the power supply (+12V) as shown in the diagram below.

IPG-IPC

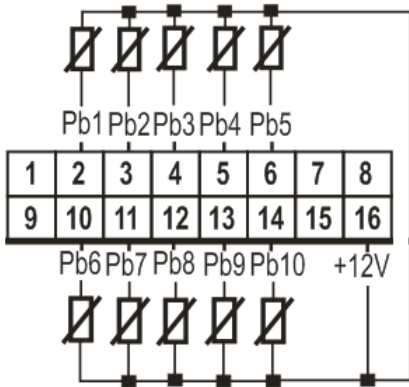

IPG-IPC 4 DIN

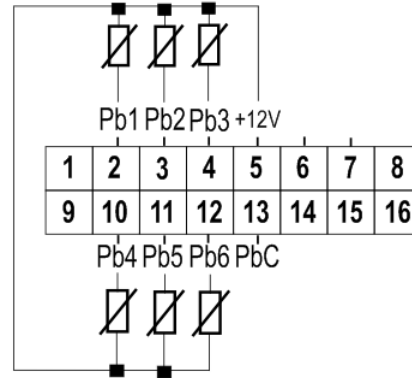

Recommendations:

- follow the diagram of the device used, for the numbering.
- the configuration is determined by the application.

7.3.4 Pressure transducers and current probes IPG800 Series (0 - 20mA, 4 - 20mA)

2-row sensors that require +12Vdc power supply.

Two sensors must be connected through one of the inputs (from Pb6 to Pb7) and the power supply (+12V) as shown in the diagram below.

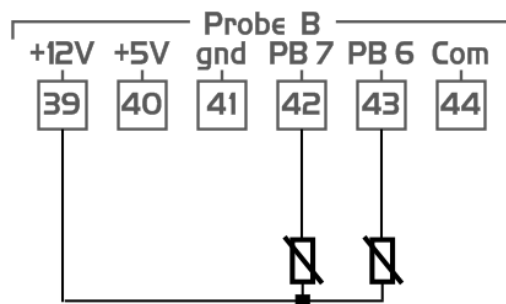

Recommendations:

- follow the diagram of the device used, for the numbering.
- the configuration is determined by the application.

7.3.5 Pressure transducers and ratiometric pressure transducers (0 - 5V)

3-row sensors that require +5Vdc power supply.

Each sensor must be connected through one of the inputs (from Pb1 to Pb10) and the power supply (+5V/GND) as shown in the diagram below.

IPG-IPC

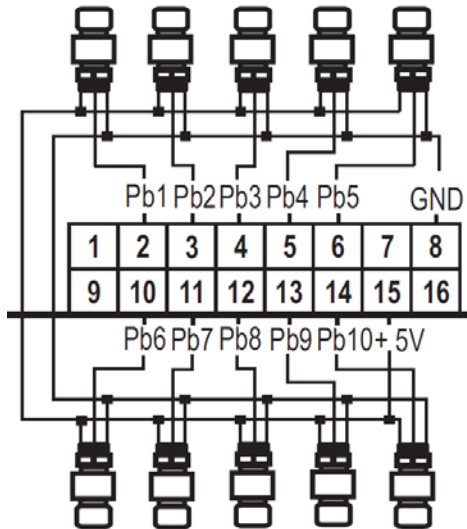

IPG-IPC 4 DIN

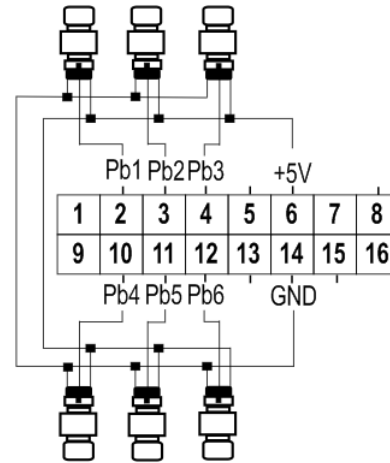

Recommendations:

- follow the diagram of the device used, for the numbering.
- the configuration is determined by the application.

7.3.6 Pressure transducers and ratiometric pressure transducers IPG800 Series (0 - 5V)

3-row sensors that require +5Vdc power supply.

Two sensors must be connected through one of the inputs (from Pb6 to Pb7) and the power supply (+5V/GND) as shown in the diagram below.

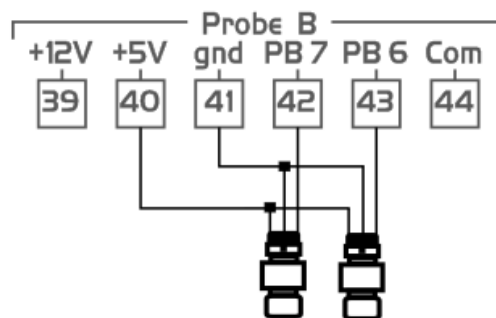

Recommendations:

- follow the diagram of the device used, for the numbering.
- the configuration is determined by the application.

7.3.7 Live probes (0 - 1V, 0 - 5V, 0 - 10V)

3-row sensors that require +12Vdc power supply.

Each sensor must be connected through one of the inputs (from Pb1 to Pb10) and the power supply (+12V/GND) as shown in the diagram below.

IPG-IPC

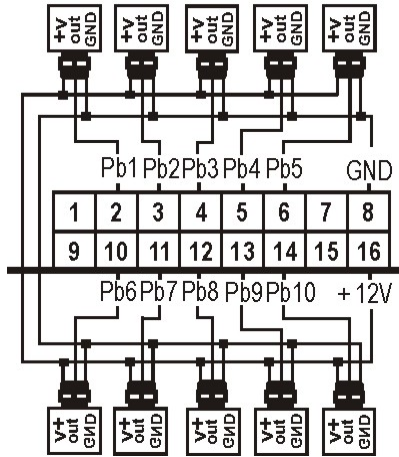

IPG-IPC 4 DIN

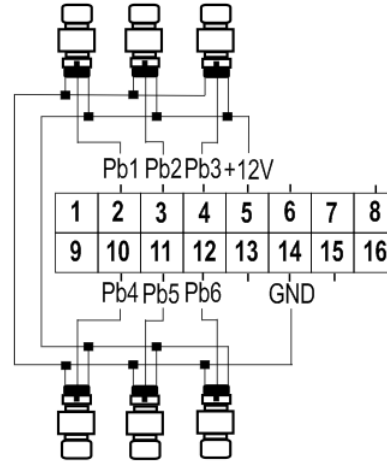

Recommendations:

- follow the diagram of the device used, for the numbering.
- the configuration is determined by the application.

7.3.8 Live probes IPG800 Series (0 - 1V, 0 - 5V, 0 - 10V)

3-row sensors that require +12Vdc power supply.

Two sensors must be connected through one of the inputs (from Pb6 to Pb7) and the power supply (+12V/GND) as shown in the diagram below.

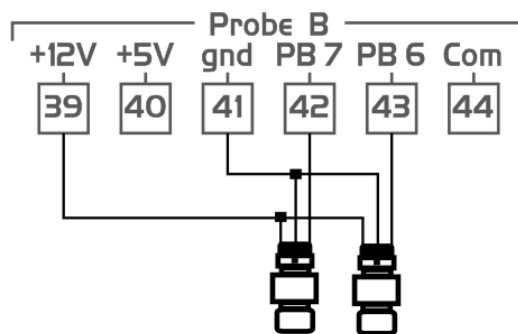

Recommendations:

- follow the diagram of the device used, for the numbering.
- the configuration is determined by the application.

7.3.9 Probes and transducers with 24Vac/dc power supply

3 or 4-row sensors that require +24Vac/dc power supply

Each sensor must be connected through one of the inputs (from Pb1 to Pb10), whereas the power supply as shown in the diagram below.

This is an example for versions IPG-IPC.

For all the others version, verify the correct number of the pin in the connector.

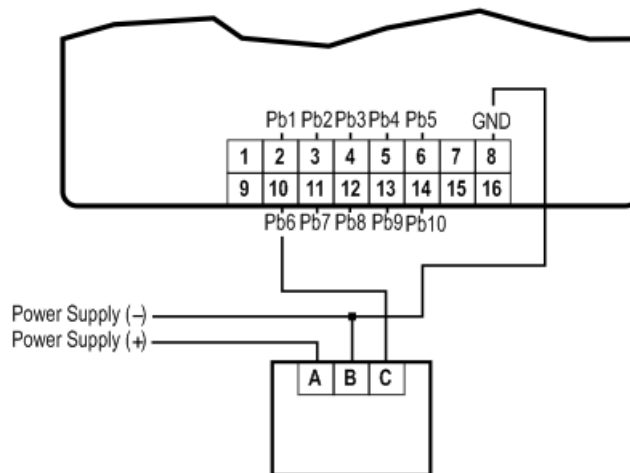
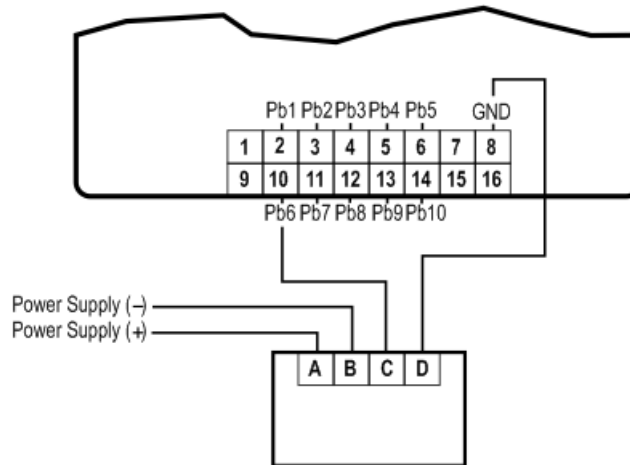

Recommendations:

- respect the "+" and "-" polarities of the power supply.
- the power supply of the sensor must be separate from that of the programmable controller
- follow the diagram of the device used, for the numbering.
- the configuration is determined by the application.

7.3.10 Probes and transducers with 24Vac/dc power supply IPG800 Series

3 or 4-row sensors that require +24Vac/dc power supply

Each sensor must be connected through one of the inputs (from Pb6 to Pb7), whereas the power supply as shown in the diagram below.

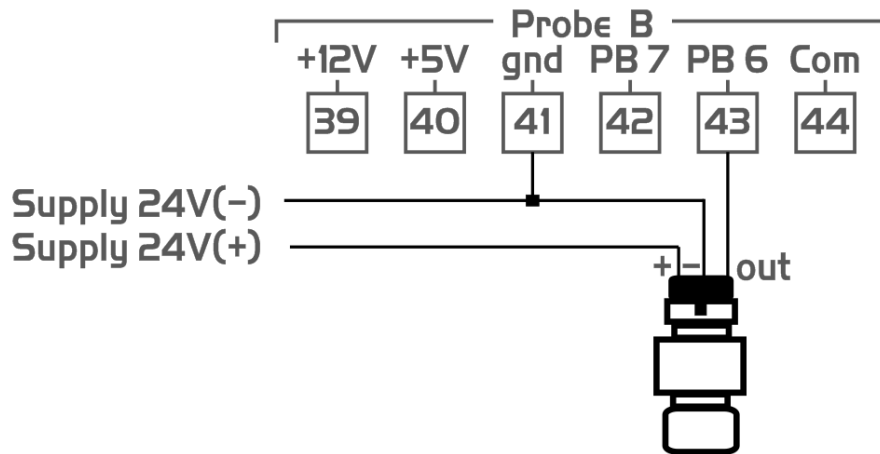

Recommendations:

- respect the "+" and "-" polarities of the power supply.
- the power supply of the sensor must be separate from that of the programmable controller
- follow the diagram of the device used, for the numbering.
- the configuration is determined by the application.

7.4 CONNECTION OF THE DIGITAL INPUTS

The digital inputs in the programmable controllers and expansions are fully configurable. Depending on the model used, the digital inputs can be used as potential free or live (24Vac/dc) digital inputs.

7.4.1 Potential-free digital inputs

IPG100, IPC100 and IPX106D versions

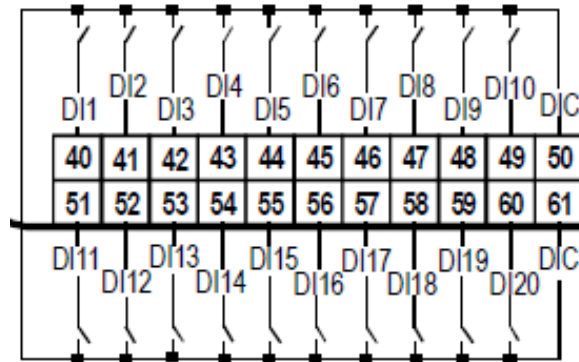

IPG200, IPX125D, IPX115D, IPX215D, IPX215D VERSIONS

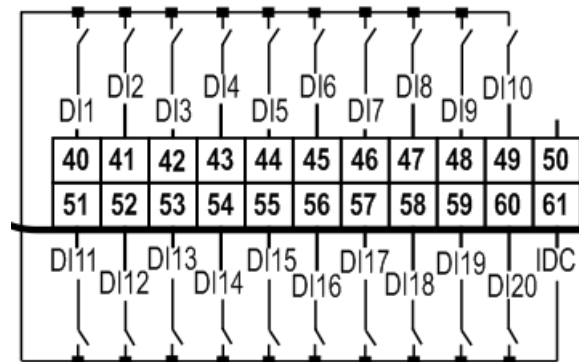

IPG108D, IPG208D VERSION (special version not standard version)

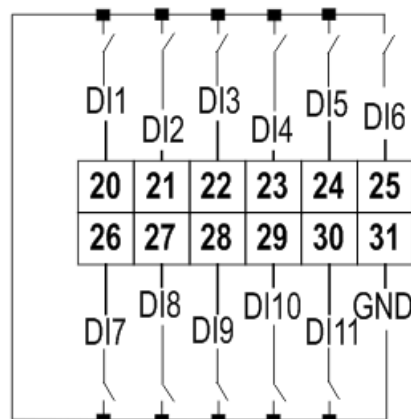

Recommendations:

- follow the diagram of the device used, for the numbering.
- the configuration is determined by the application.

7.4.2 Potential-free digital inputs IPG800 Series

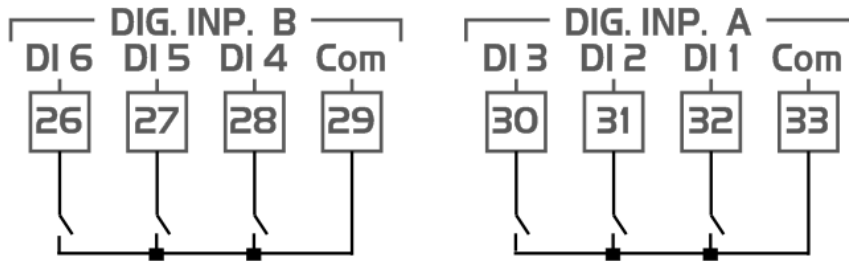

Recommendations:

- follow the diagram of the device used, for the numbering.
- the configuration is determined by the application.

7.4.3 Live digital inputs (24Vac/dc)

IPG200D, IPX115D, IPX125D, IPX215D, IPX225D VERSIONS

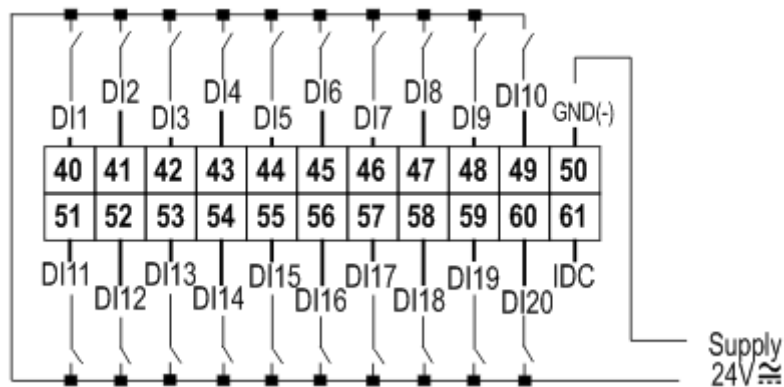

IPG108D, IPG208D, IPG108E, IPG208E VERSION (standard version)

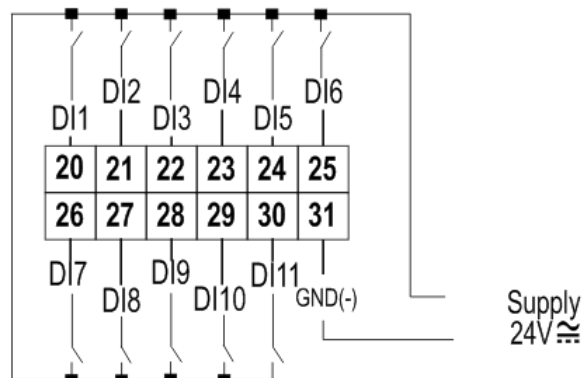

Recommendations:

- follow the diagram of the device used, for the numbering.
- the configuration is determined by the application.

7.4.4 Power supply 24Vac digital inputs IPG800 Series

On request (different Part Number) it is possible to have the Opto-Insulated digital input but with power supply 24Vac (in this case no potential free contacts).

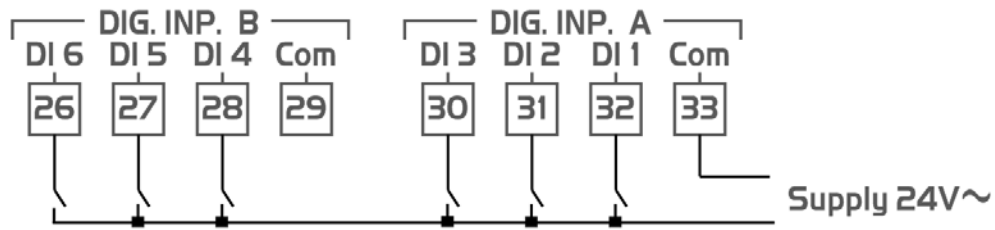

Recommendations:

- follow the diagram of the device used, for the numbering.
- the configuration is determined by the application.

7.5 CONNECTION OF THE ANALOGUE OUTPUTS

Depending on the model and configurations, it is possible to use analogue outputs such as 0 - 10Vdc, 4 - 20mA or PWM (the PWM configuration requires the Dixell XVxx module to be used for the fan speed to be controlled).

NOTE: the analogue outputs in certain models are not opto-insulated. In this case, any devices that require 24Vac/dc power supply must be powered separately with another transformer.

7.5.1 0 - 10V, 4 - 20mA Analogue output for condensation control

IPG-IPC VERSION

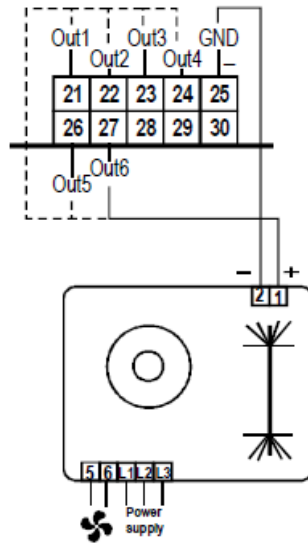

IPG108, IPG208 VERSION

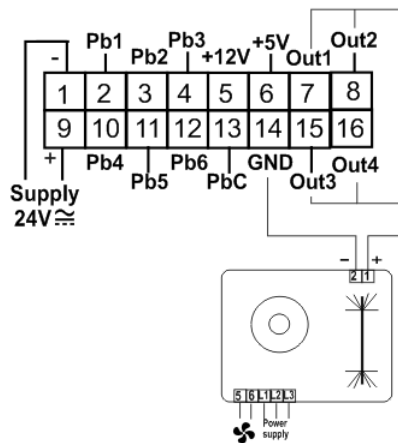

Recommendations:

- follow the diagram of the device used, for the numbering.
- the configuration is determined by the application.

7.5.2 0-10Vdc, 4-20mA Analogue output for fan speed control IPG800 Series

The three analog outputs AO1, AO2 and AO3 can be used to drive an external fan speed control (Dixell XV series) through the 0-10Vdc or 4-20mA.

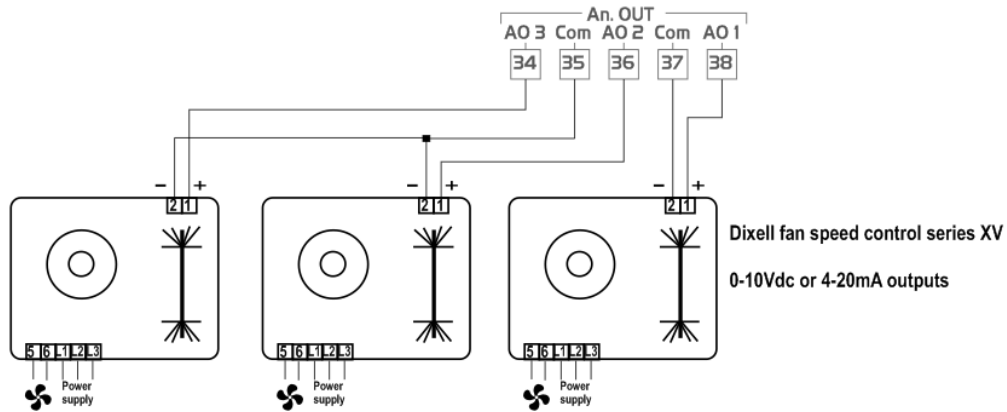

Recommendations:

- follow the diagram of the device used, for the numbering.
- the configuration is determined by the application.

7.5.3 PWM analogue output for condensation control

IPG100 VERSIONS (not available for IPG200 and 4 DIN)

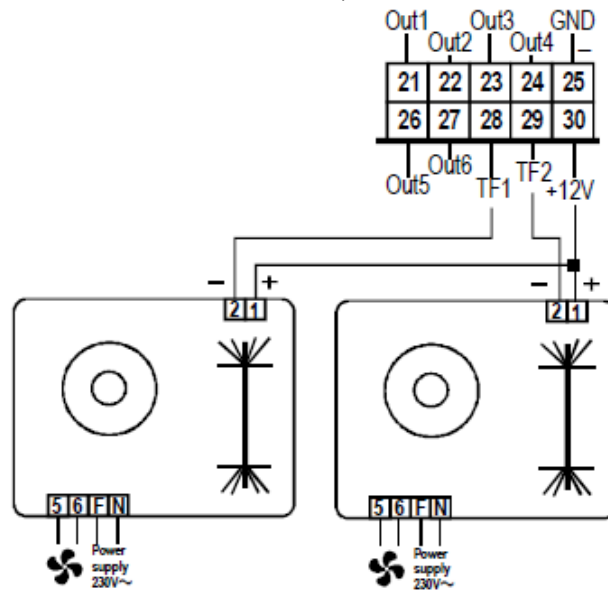

Recommendations:

- follow the diagram of the device used, for the numbering.
- the configuration is determined by the application.

7.5.4 PWM analogue output for control IPG800 Series

The analog outputs AO1 (depend on the model), can be used to drive an external fan speed control (Dixell XV series) through the PWM signal.

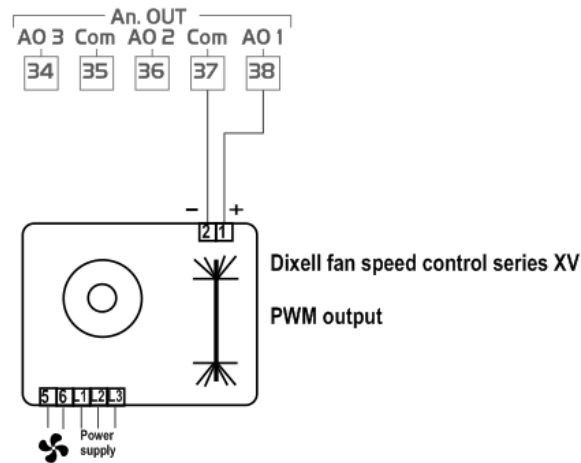

Note: the PWM is available only if the Power Supply is 24Vac.

Recommendations:

- follow the diagram of the device used, for the numbering.
- the configuration is determined by the application.

7.5.5 0 - 10V, 4 - 20mA Proportional analogue output for servomotors/actuators

IPG-IPC

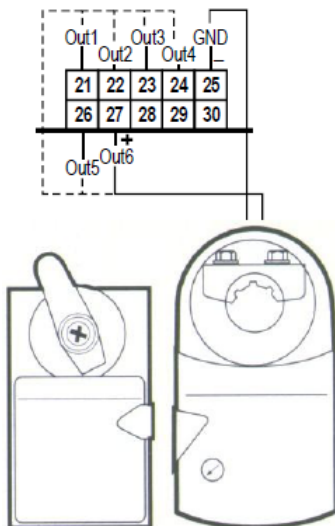

IPG 4 DIN

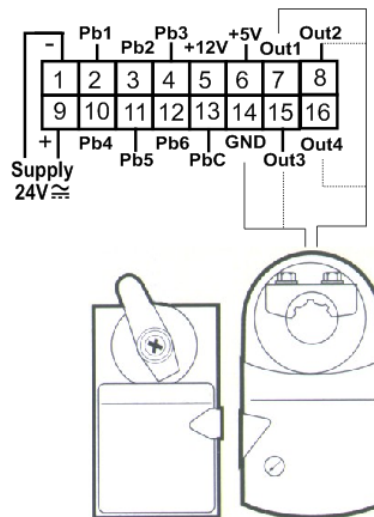

Recommendations:

- follow the diagram of the device used, for the numbering.
- the configuration is determined by the application.

7.5.6 Devices with 24Vac/dc power supply

3 or 4-row devices that require +24Vac/dc power supply

Each device must be connected through one of the outputs (from Out1 to Out6), whereas the power supply as shown in the diagram below.

This is an example for versions IPG-IPC.

For all the others version, verify the correct number of the pin in the connector.

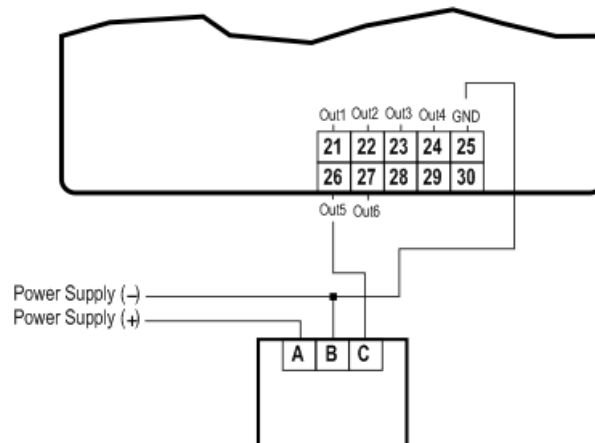
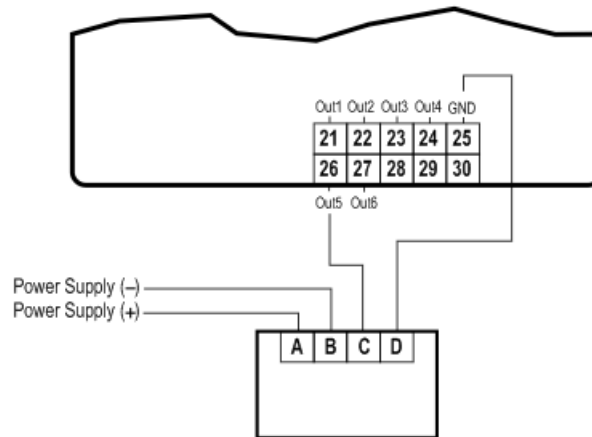

Recommendations:

- respect the "+" and "-" polarities of the power supply.
- the power supply of the device must be separate from that of the programmable controller
- follow the diagram of the device used, for the numbering.
- the configuration is determined by the application.

7.5.7 Analogue output for relays (coil power supply 12Vdc)

IPG-IPC

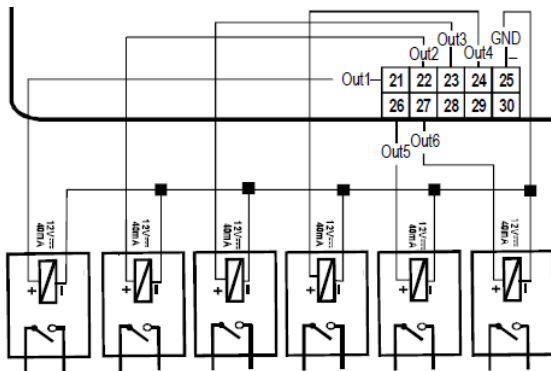

IPG 4 DIN

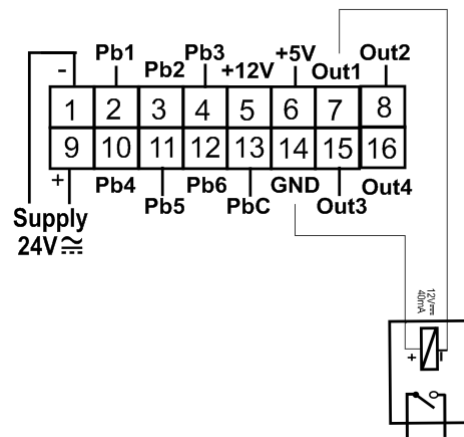

Recommendations:

- follow the diagram of the device used, for the numbering.
- the configuration is determined by the application.

7.6 CONNECTION OF THE DIGITAL OUTPUTS

Depending on the model, the digital outputs can have different connection specifications.

The relays have been split into groups, each with a separate common.

The same voltage must always be used for the various groups of relays and within each group.

For the electrical specifications, refer to the relative paragraphs of the different models.

Certain models have SSR relays (solid state relay), which are suitable to control devices where numerous commutations are required, which would not be supported by an electromechanical relay. For the electrical specifications, refer to the specifications of the model using such relays.

7.7 ELECTRONIC EXPANSION VALVE DRIVER IPG800 SERIES

7.7.1 GENERAL RULES

IPG800 is able to drive a wide range of stepper valves, in the following table are indicated the maximum values of current that the actuator can supply to the stepper wiring. When the EEV valve is connected it is necessary to use the TF40D transformer to power supply the IPG800 and the maximum current of each winding of the valve must be 0,3A.

NOTE: the electrical power absorption of the valve can be unrelated to refrigeration power that valve has. Before using the actuator, please, read the technical manual of the valve supplied by the manufacturer and check the maximum current used to drive the valve in order to verify that they are lower than that indicated here above.

7.7.2 ELECTRICAL CONNECTIONS

The IPG800 driver can manage the following electronic expansion valves:

Connection numbering	SER Sporland	SAGINOMIYA	EX3 Emerson	EXM/EXL Emerson
V4 VALVE	ORANGE	ORANGE	WHITE	WHITE
V2 VALVE	RED	RED	BROWN	ORANGE
V3 VALVE	YELLOW	YELLOW	BLACK	YELLOW
V1 VALVE	BLACK	BLACK	BLUE	BLUE
+12V VALVE (Common)	GRAY	GRAY	GRAY	BROWN

7.8 CANBUS CONNECTION

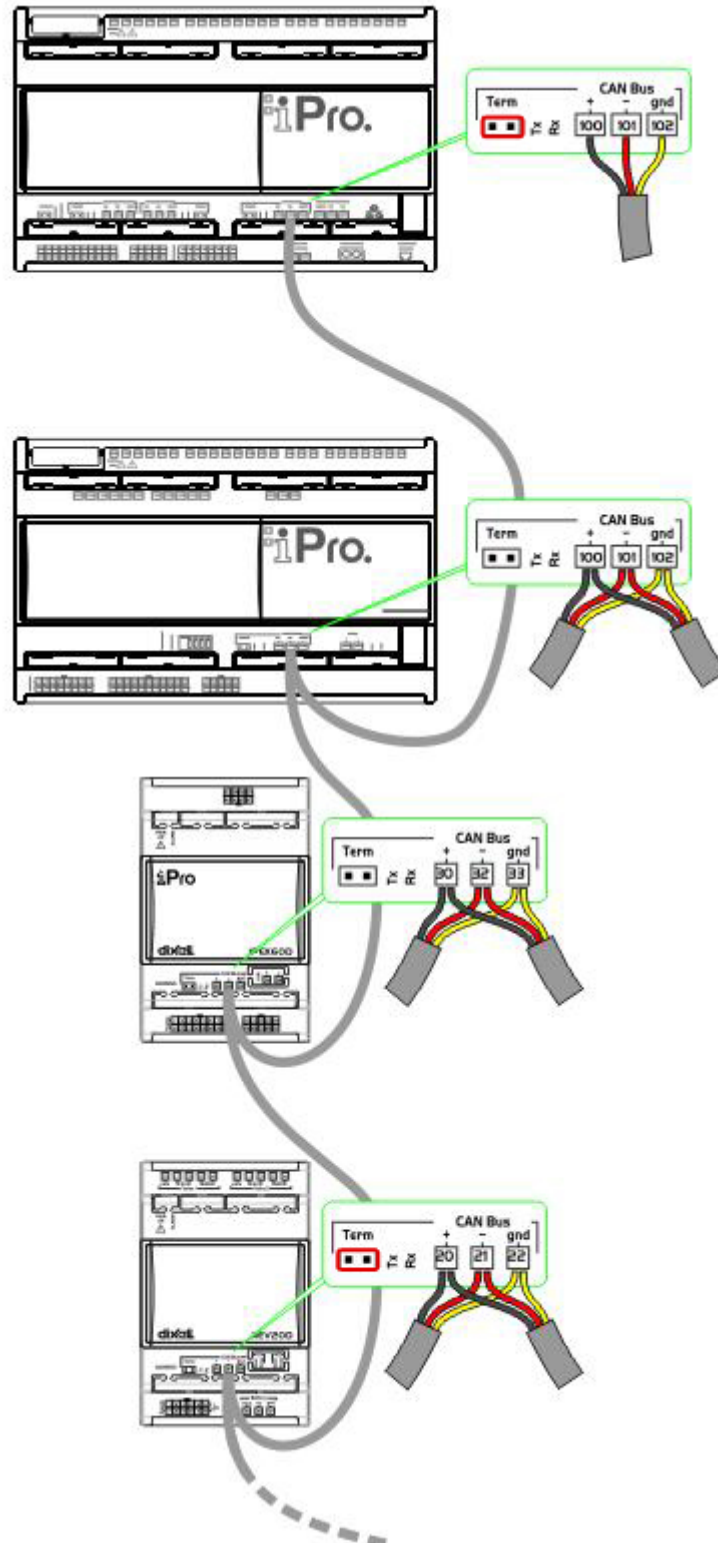

Recommendations:

- follow the diagram of the device used, for the numbering.

7.9 RS485 SLAVE CONNECTIONS

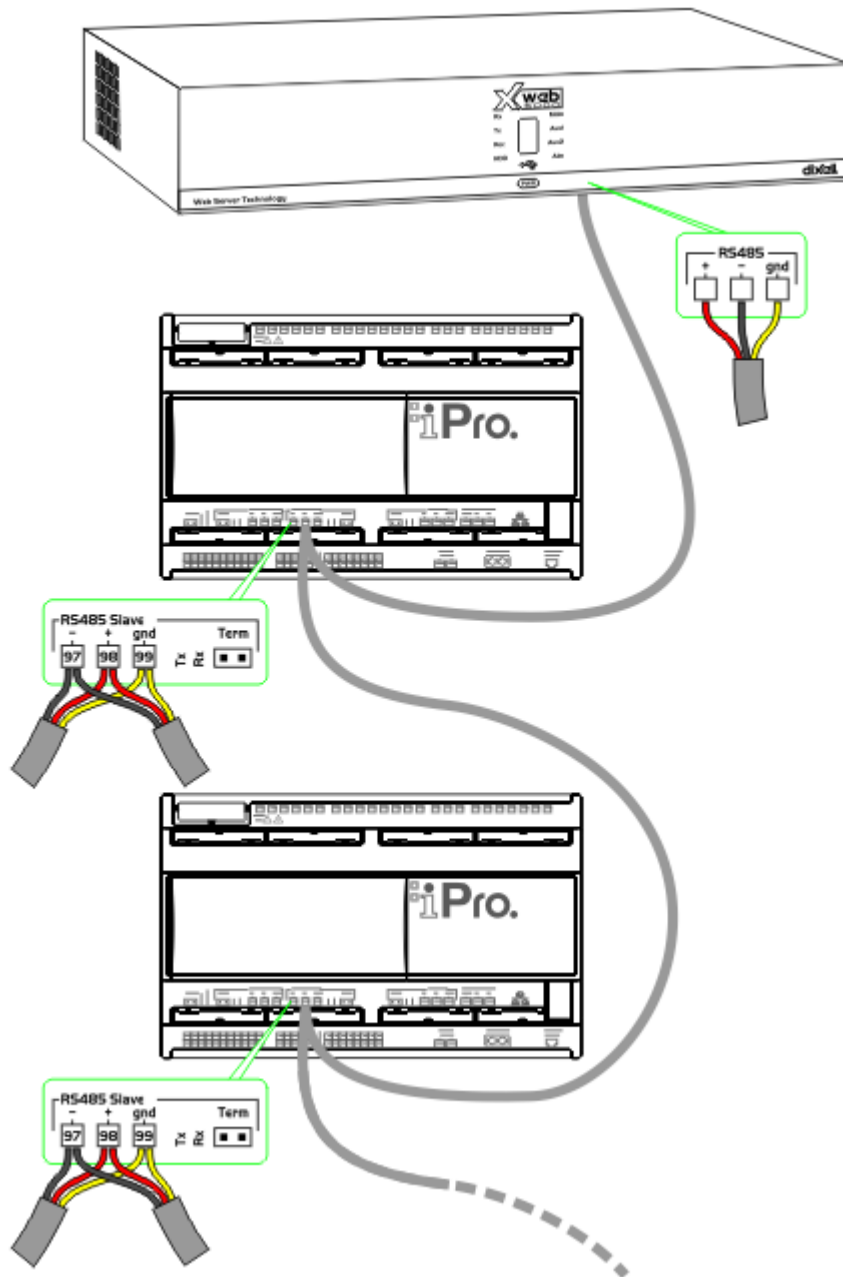

Recommendations:

- follow the diagram of the device used, for the numbering.

7.10 RS485 MASTER CONNECTION

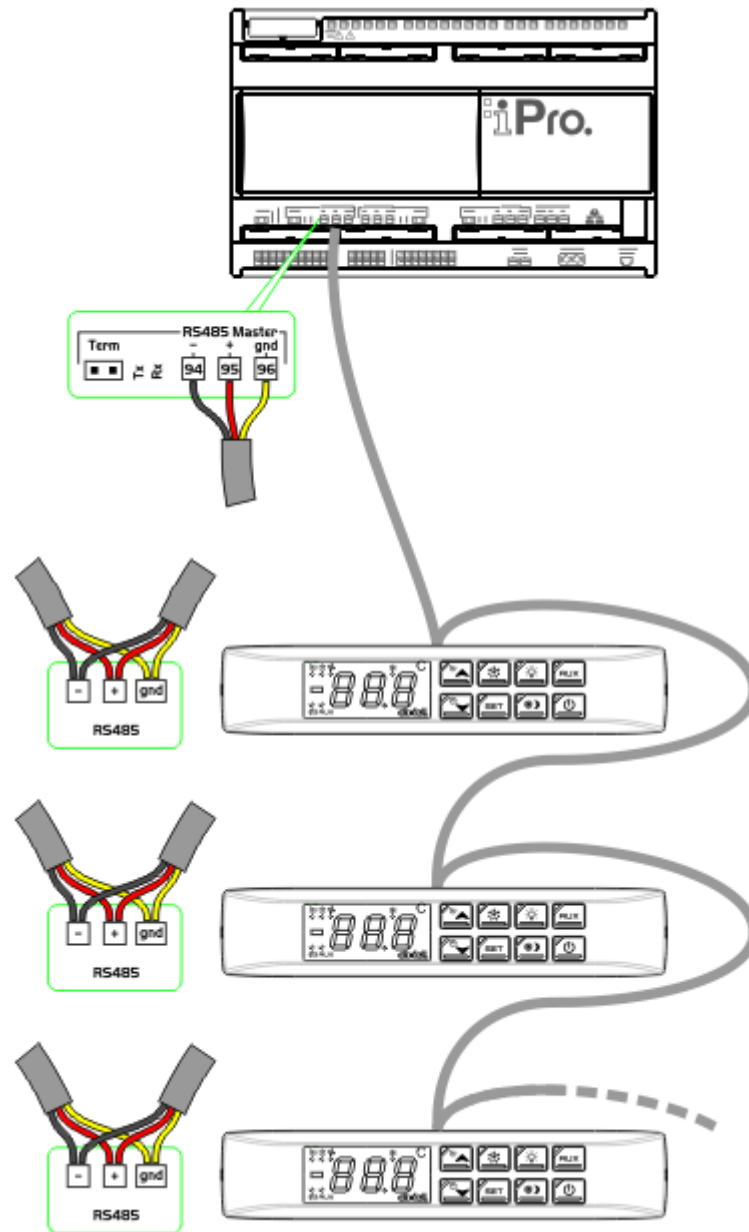

Recommendations:

- follow the diagram of the device used, for the numbering.

Dixell



Dixell S.r.l. - Z.I. Via dell'Industria, 27 - 32010 Alpago (BL) ITALY
Tel. +39.0437.9833 r.a. - Fax +39.0437.989313 - EmersonClimate.com/Dixell - dixell@emerson.com